

To Members of the Planning Committee

Cllr. Lee Breckon JP (Chairman)
Cllr. Mike Shirley (Vice-Chairman)

Cllr. Cheryl Cashmore
Cllr. Tony Deakin
Cllr. Richard Holdridge

Cllr. Dillan Shikotra
Cllr. Bob Waterton
Cllr. Bev Welsh

Cllr. Neil Wright

Dear Councillor,

A meeting of the **PLANNING COMMITTEE** will be held in the Council Chamber - Council Offices, Narborough on **THURSDAY, 29 JUNE 2023** at **4.30 p.m.**. Please find attached a number of supplemental items that are required for the meeting and are in addition to the agenda and report pack that has already been circulated.

Yours faithfully



Louisa Horton
Corporate Services Group Manager and Monitoring Officer

SUPPLEMENTAL ITEMS

4. Officers presentation to Committee (Pages 3 - 76)

To consider the reports of the Development Services Team Leader.



This page is intentionally left blank

Welcome to the Planning Committee meeting on 29th June 2023.

Page 3

The meeting is due to start at 16.30.

Agenda Item 4

Planning Committee

29 June 2023

Planning application 21/1386/FUL

Land at Hill Farm, Earl Shilton Road, Thurlaston

Page 5

Construction of a 36.1 hectare solar park to include the installation of solar photovoltaic panels to generate electricity (up to 22MW) with associated substations, transformers, inverters, perimeter fencing, access tracks, CCTV and landscaping.

Site Location

Page 6



The Site

Page 7

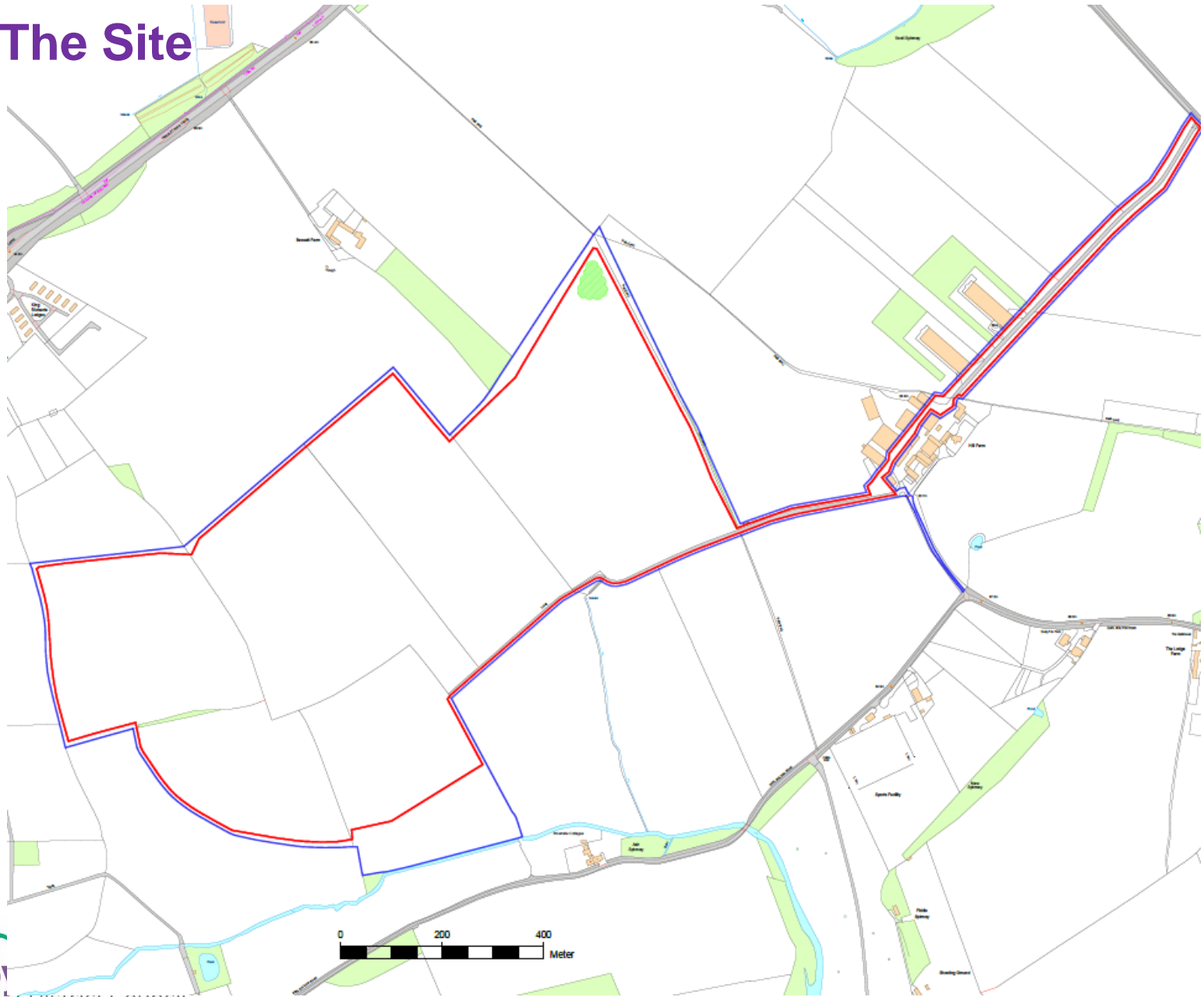









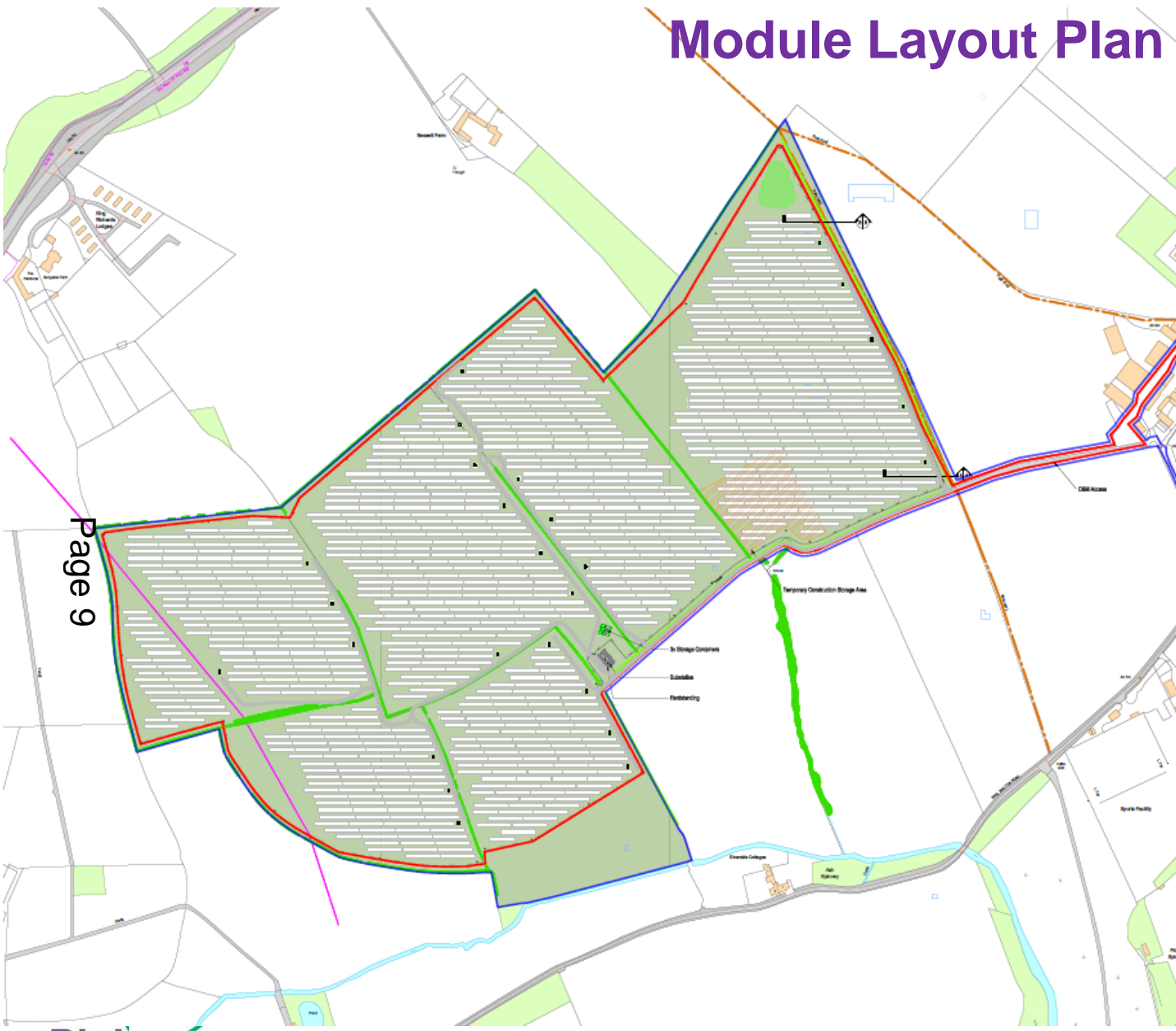









The Site



Page 8

Module Layout Plan



- Legend:**
-  Area within control of applicant
 -  Solar Panel
 -  fence
 -  gate (6m wide)
 -  transformer station
 -  gravel road (3,5m width)
 -  storage container
 -  Temporary construction compound
 -  Area for biodiversity gain / habitat improvement
 -  Substation
 -  Water Main
 -  Public right of way
 -  CCTV Camera Poles
 -  Proposed New Hedgerow
 -  Existing Hedgerow
 -  Proposed Woodland
 -  Hardstanding
 -  Planning application area

Page 9

Module mounting details

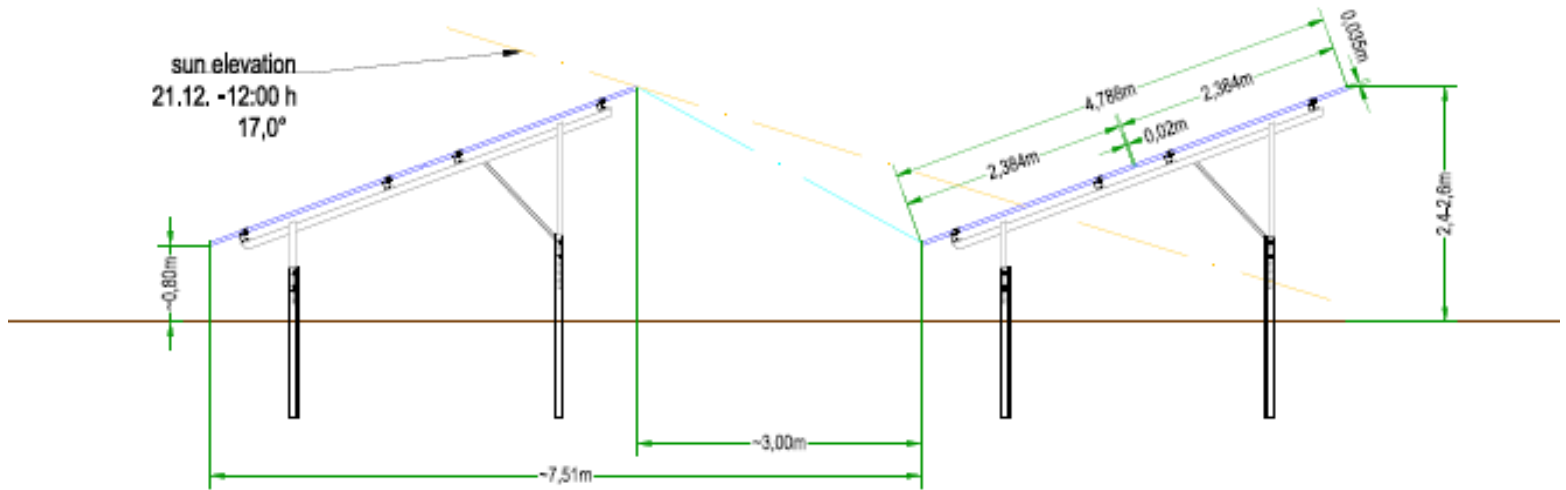

Page 10

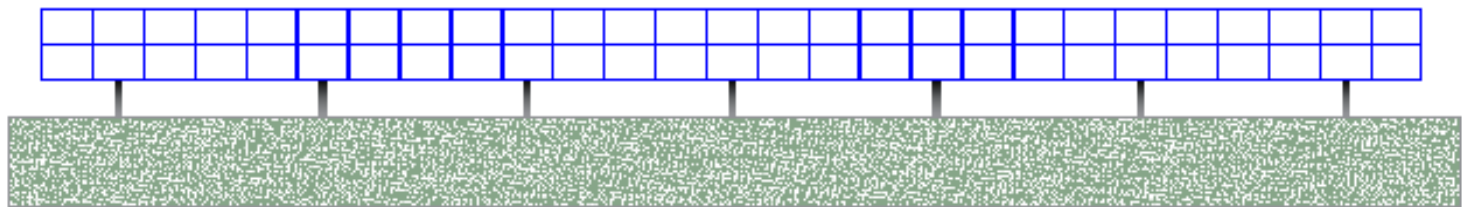

Transformer Details

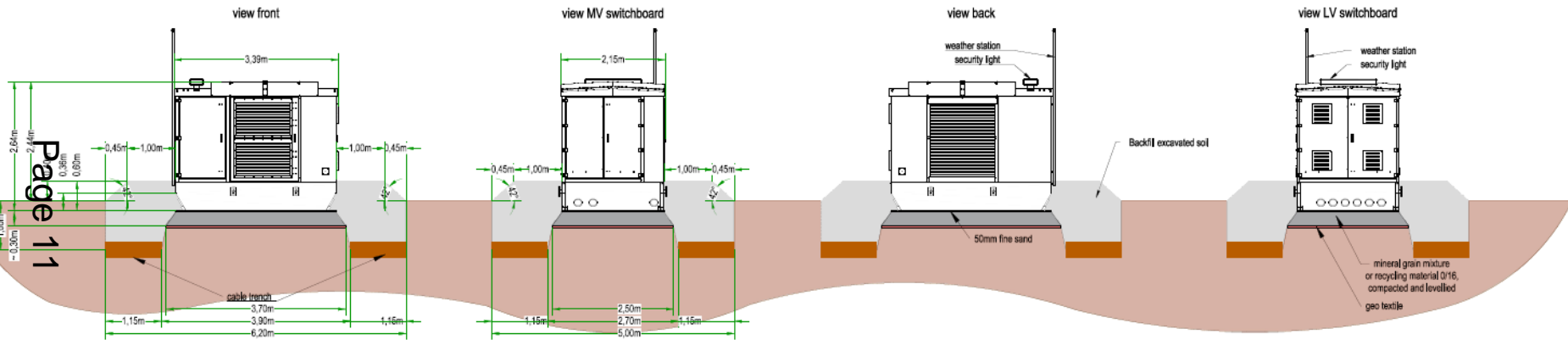

Substation Details

Page 12

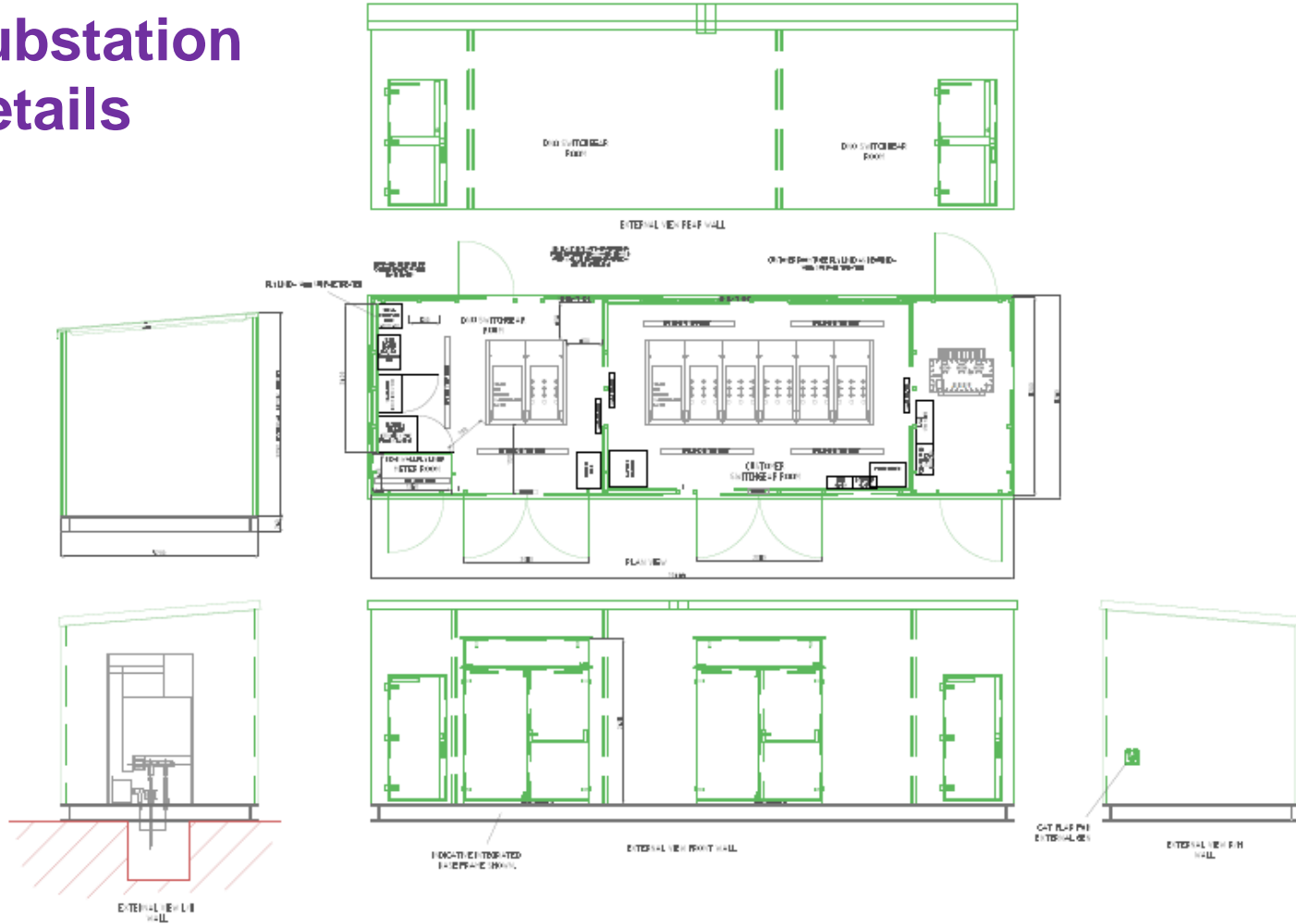

Container storage details

* color: any RAL color possible

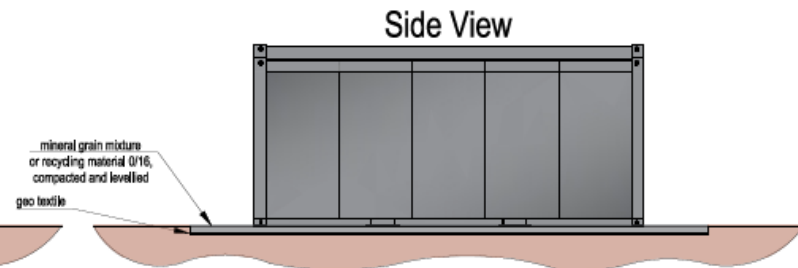
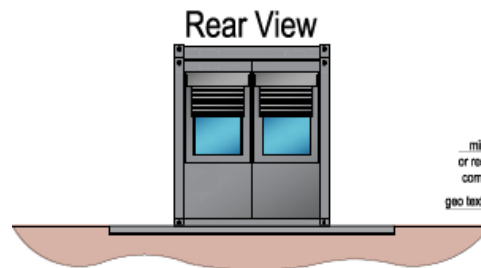
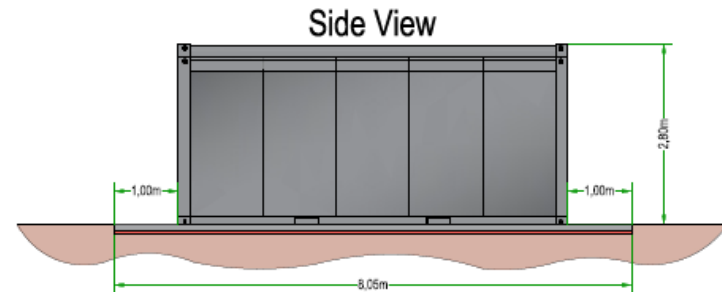
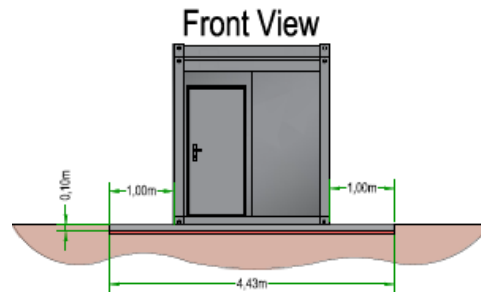
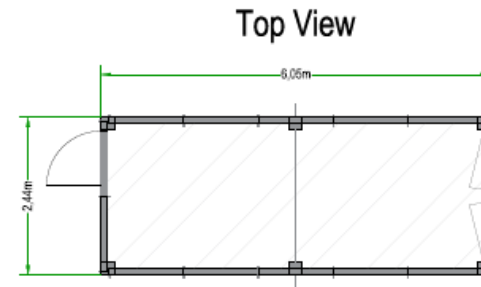

Security fencing

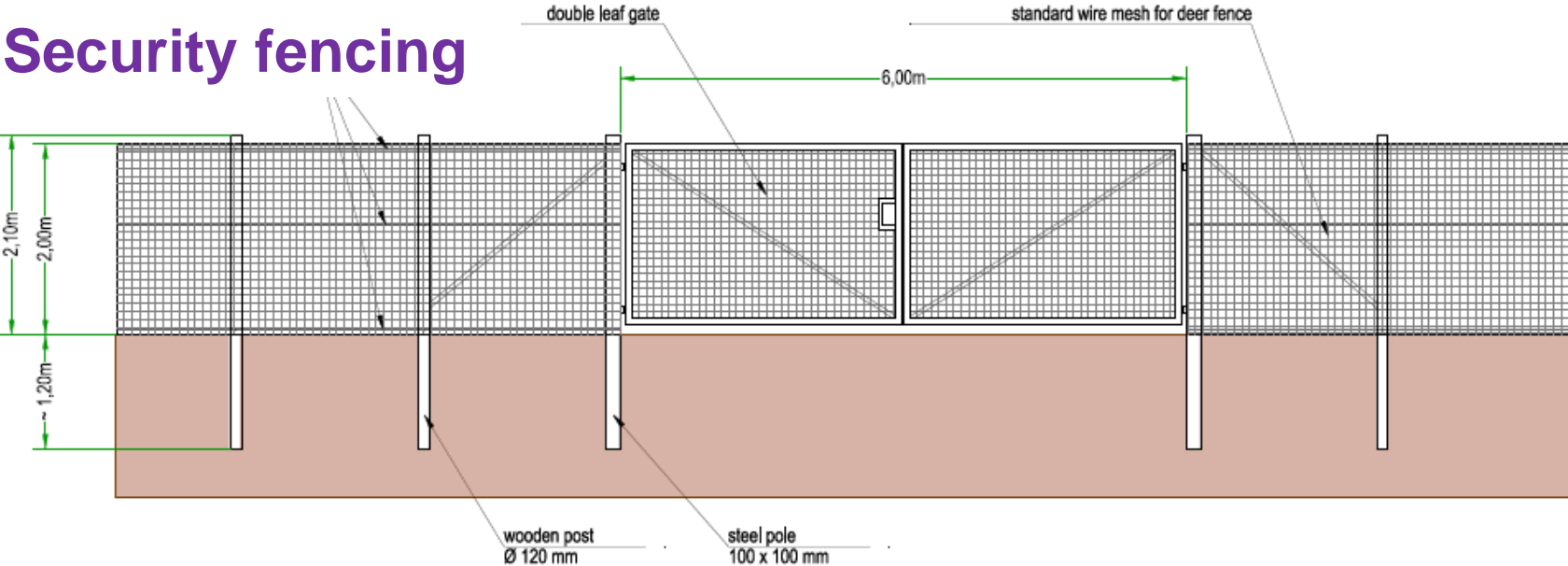

Page 14

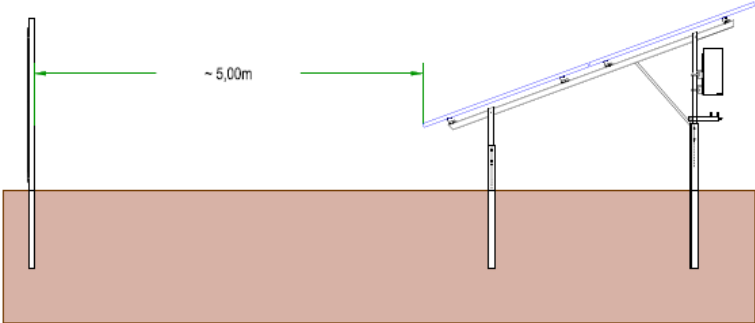

Gravel road detail

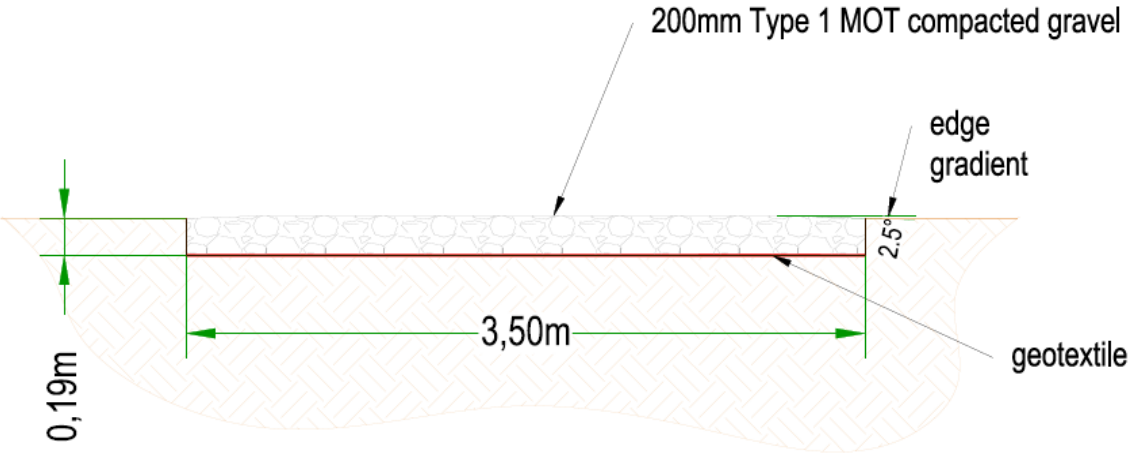

CCTV detail

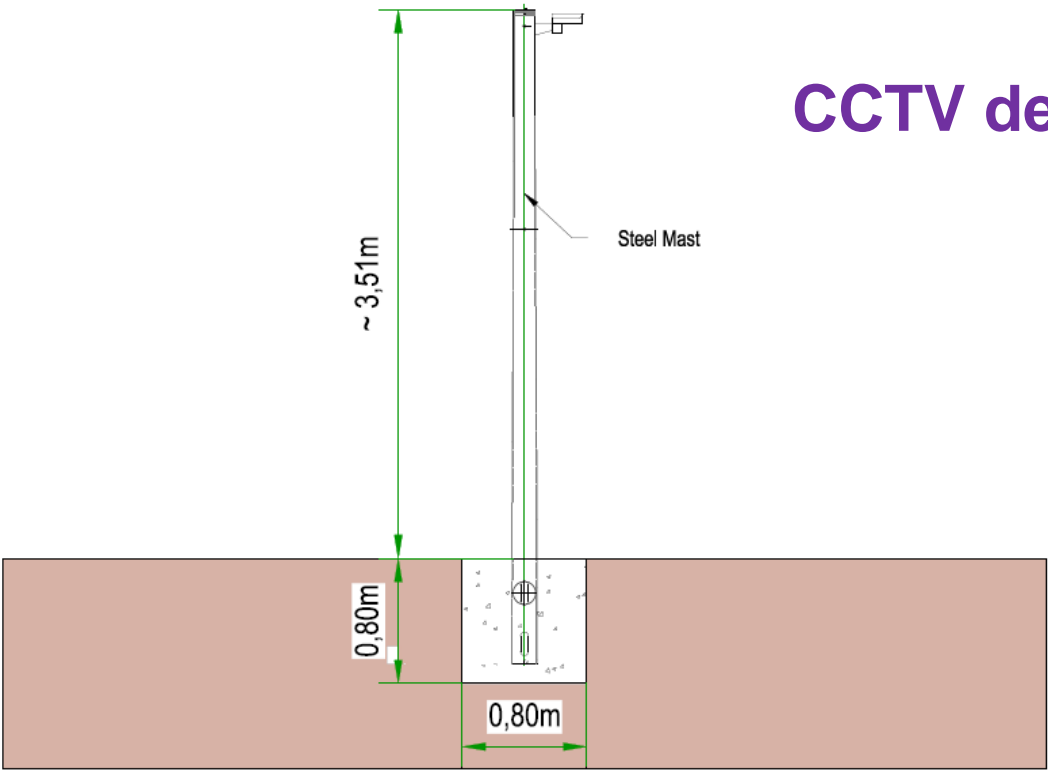

Landscape Masterplan

Proposed woodland copse provides selective screening and enclosure from the nearby public rights of way and scattered elevated residential properties to the north, supplementing the adjacent existing and proposed hedgerow.

Existing robust hedgerow enhanced with selected scattered native tree planting to provide added enclosure and screening.

Proposed hedgerow to the west of the public right of way provides screening and enclosure of the proposed solar panels, including ancillary buildings whilst also strengthening the regular landscape pattern and providing nature conservation and biodiversity benefits

Strong boundary vegetation of hedgerows, mature trees and linear tree belts protected and retained with any gaps in-filled with native hedgerow species to promote enclosure, landscape pattern and biodiversity.

Rough grassland buffers managed for biodiversity.

Wide rough grassland corridor retained around public right of way that borders the site.

Proposed solar panels set back from existing hedgerows, trees and woodland to protect their integrity as key landscape features.

Opportunity to strengthen the northern boundary, which appears intermittent in places, with additional hedgerow and scattered tree planting to minimise impacts from Bassetts Farm and adjacent caravan park to the north.

Page 16







Ongoing hedgerow management to be relaxed with trimming once every 2-3 years, staggered across the site to encourage flowering/fruitlet and thereby providing a greater abundance of foraging resources for wildlife, including birds and invertebrates. Trimming to be carried out in late Winter to prolong habitat resources but prior to the commencement of the bird nesting season.

Grassland left free from development and managed for biodiversity including ground nesting birds.



Proposed hedgerow to the south and east provides screening and enclosure to the proposed development, particularly when perceived from Earl Shilton Road to the south and from the rear of Riverside Cottages

Key







Proposed

-  Solar panels
-  Access
-  2m high post and wire deer fence
-  Service buildings / transformers
-  Crushed stone access track
-  CCTV poles

Existing

-  Hedgerows and trees to be protected and retained. Hedgerows managed to a minimum of 2.6m high and any gaps in-filled with native species
-  Public right of way
-  Track

Landscape and Ecological Mitigation

-  Proposed grass mix that supports pollinators, appropriate for solar schemes, sown on any bare ground following construction activities to maintain a continuous sward.
-  Proposed rough grassland buffer
-  Proposed biodiversity field/ground nesting bird area
-  Proposed native species hedgerow
-  Proposed native species woodland copse
-  Proposed native tree planting

Viewpoint 3 from junction of footpath V67a and Earl Shilton Road (Year 1)

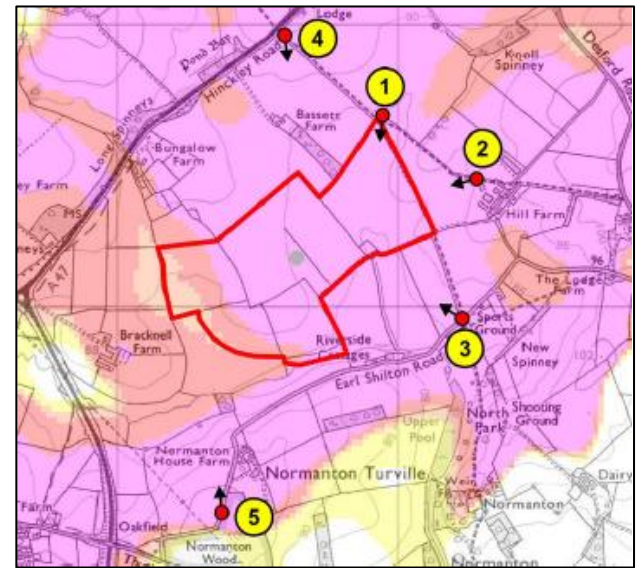

Viewpoint 3 from junction of footpath V67a and Earl Shilton Road (Year 10)

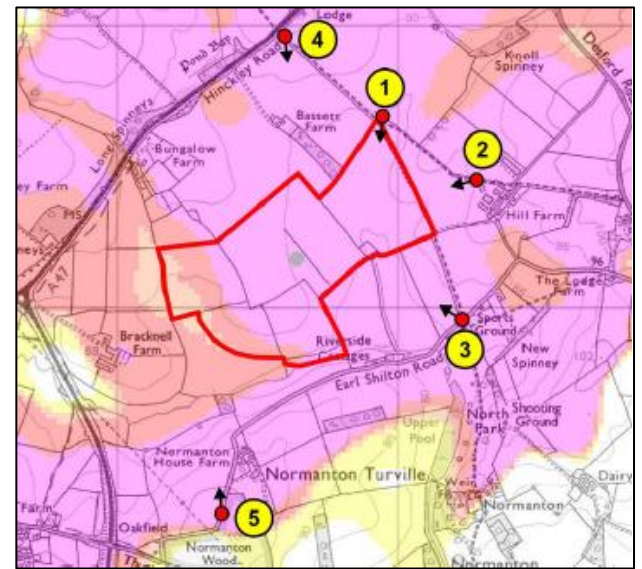

Page 18



Viewpoint 4 from junction of footpath V73 with A47 looking towards site (Year 1)

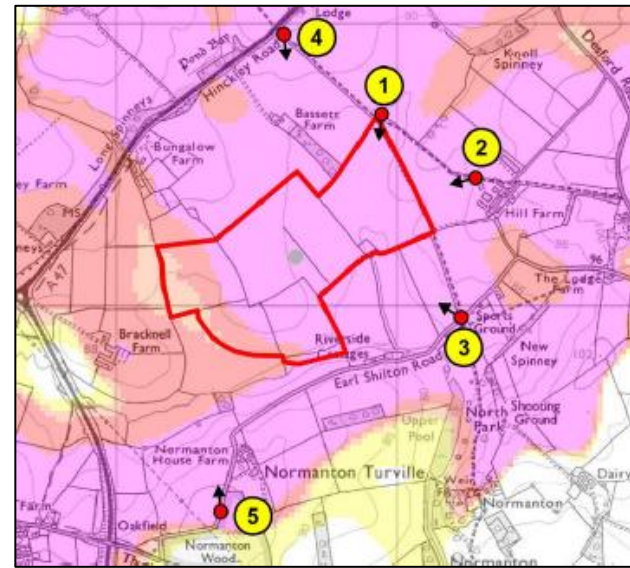

Viewpoint 4 from junction of footpath V73 with A47 looking towards site (Year 10)

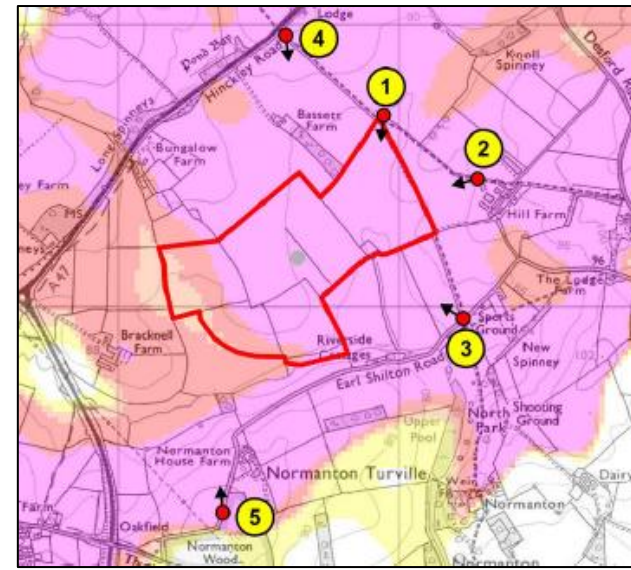



Page 20

Approximate extent of Proposed Solar Development





Cumulative Effects

Key

-  Proposed Development Boundary
-  Study Area (2.5km minimum offset)

Cumulative Schemes

-  Consented
-  Pending Planning

Solar Schemes

-  1 Desford Road
-  2 Pump Farm

Other Developments

-  3 Westfield Farm
-  4 Land north of Hill Top Farm
-  5 Earl Shilton urban extension
-  6 Land north of Neovia Logistics Services

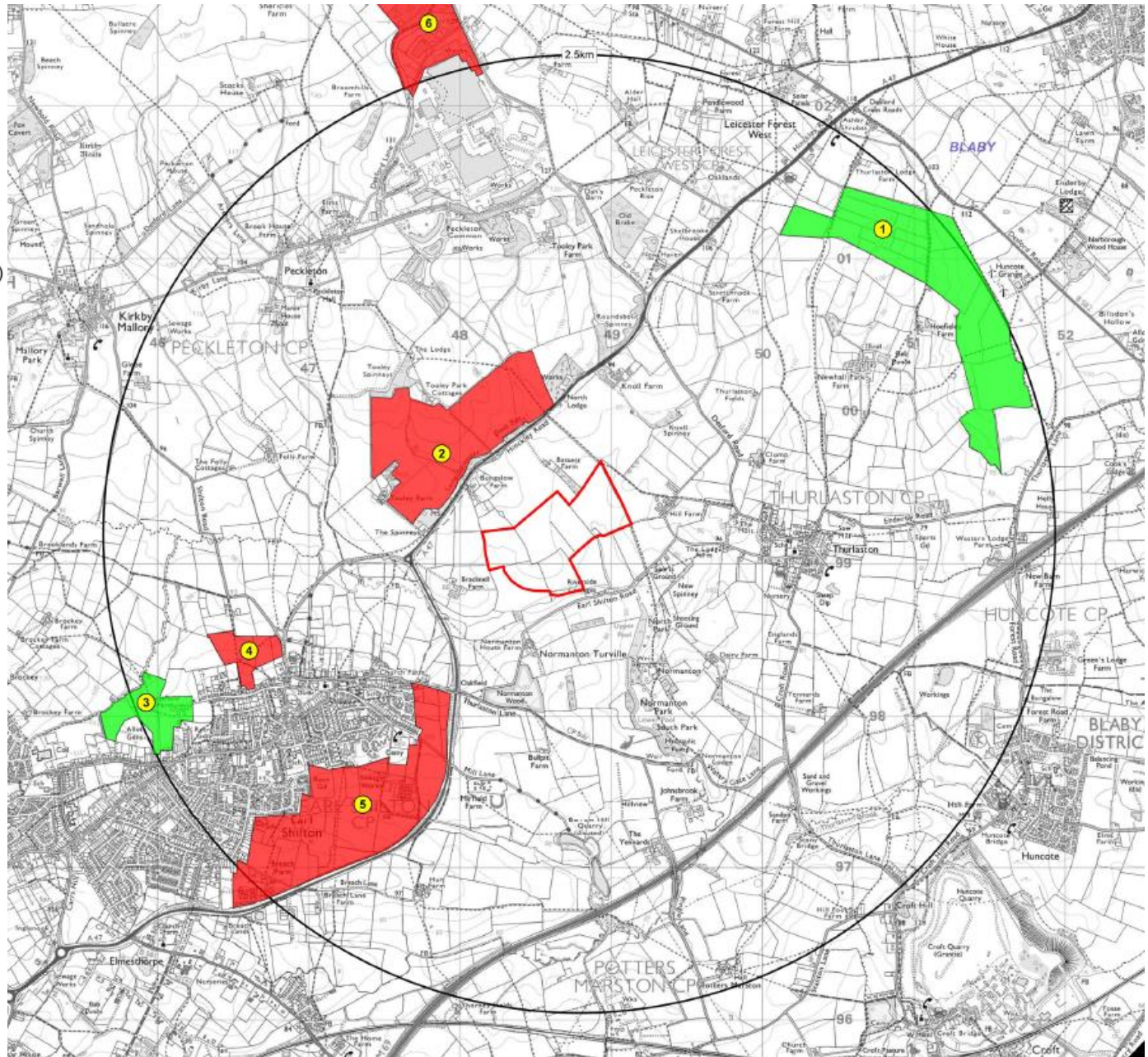

Agricultural Land Classification

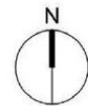
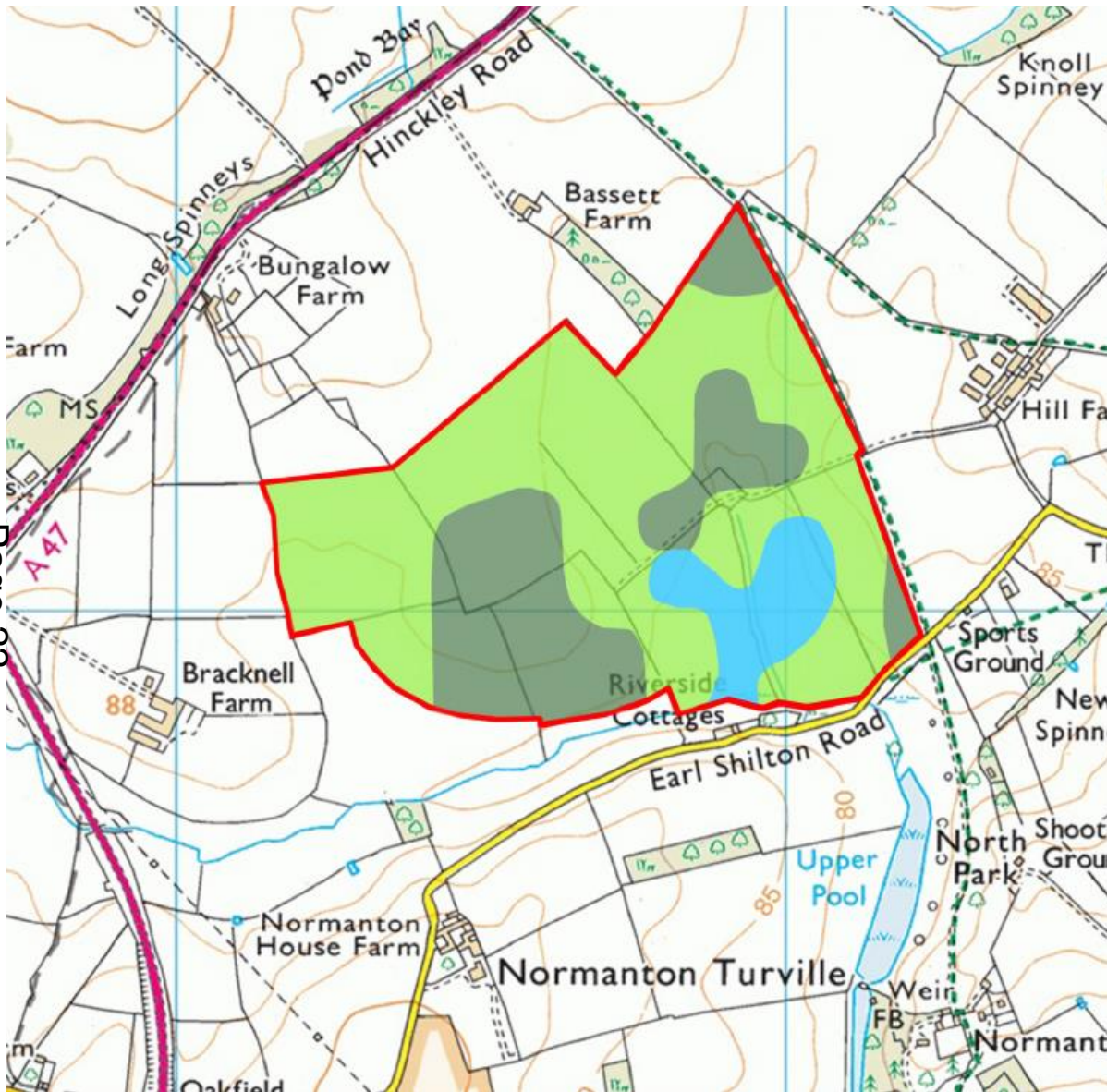

Flood Risk

Page 23

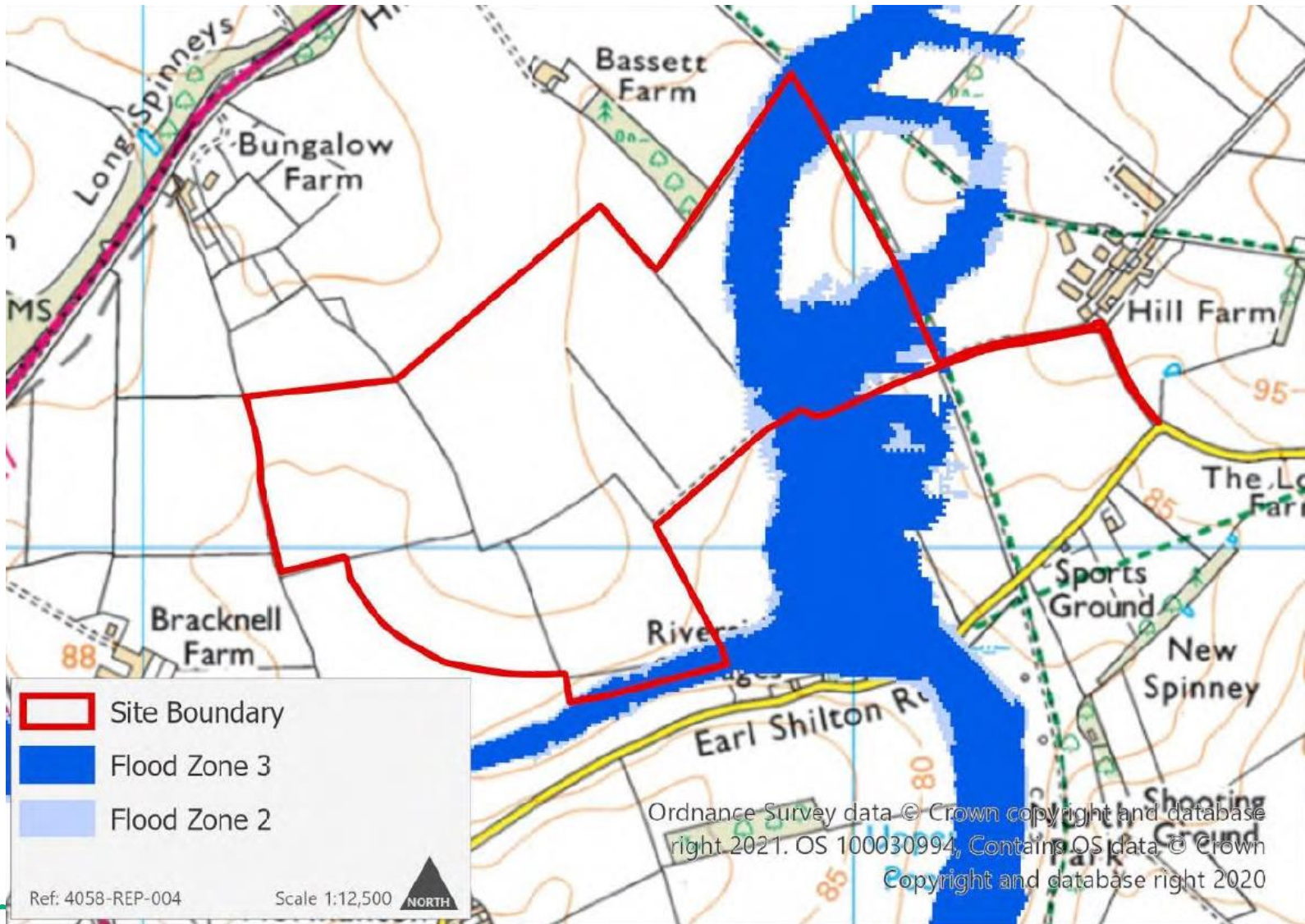

Traffic management

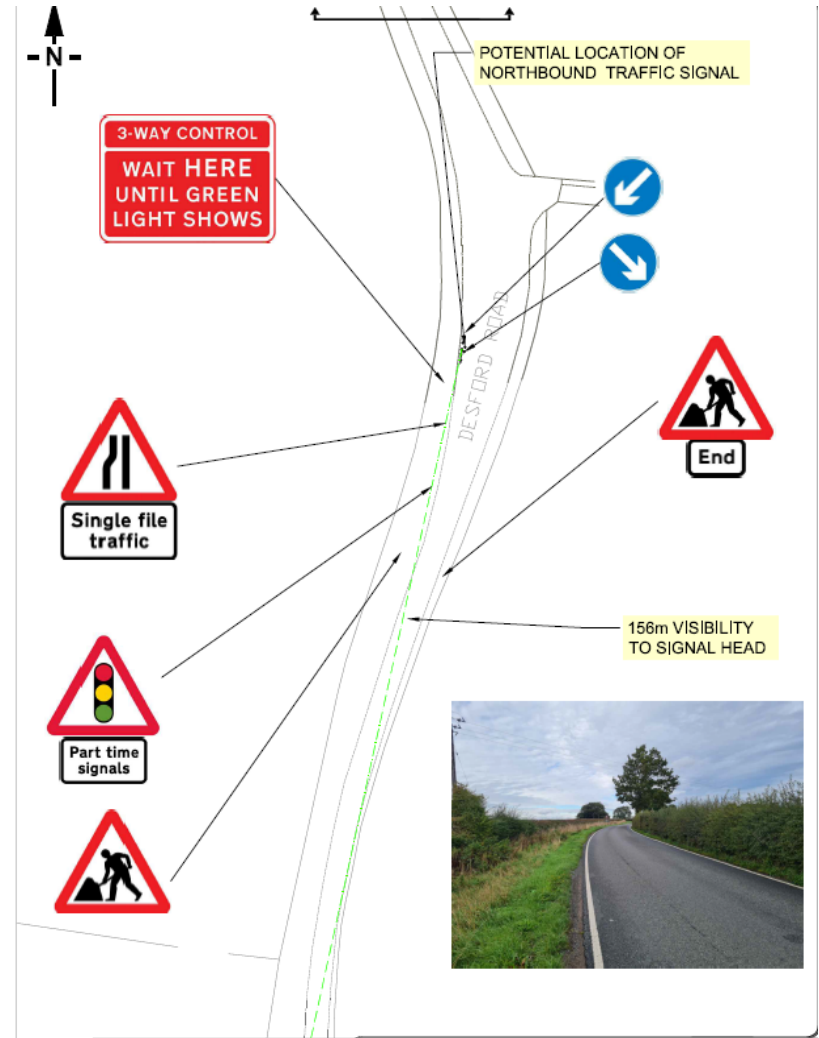
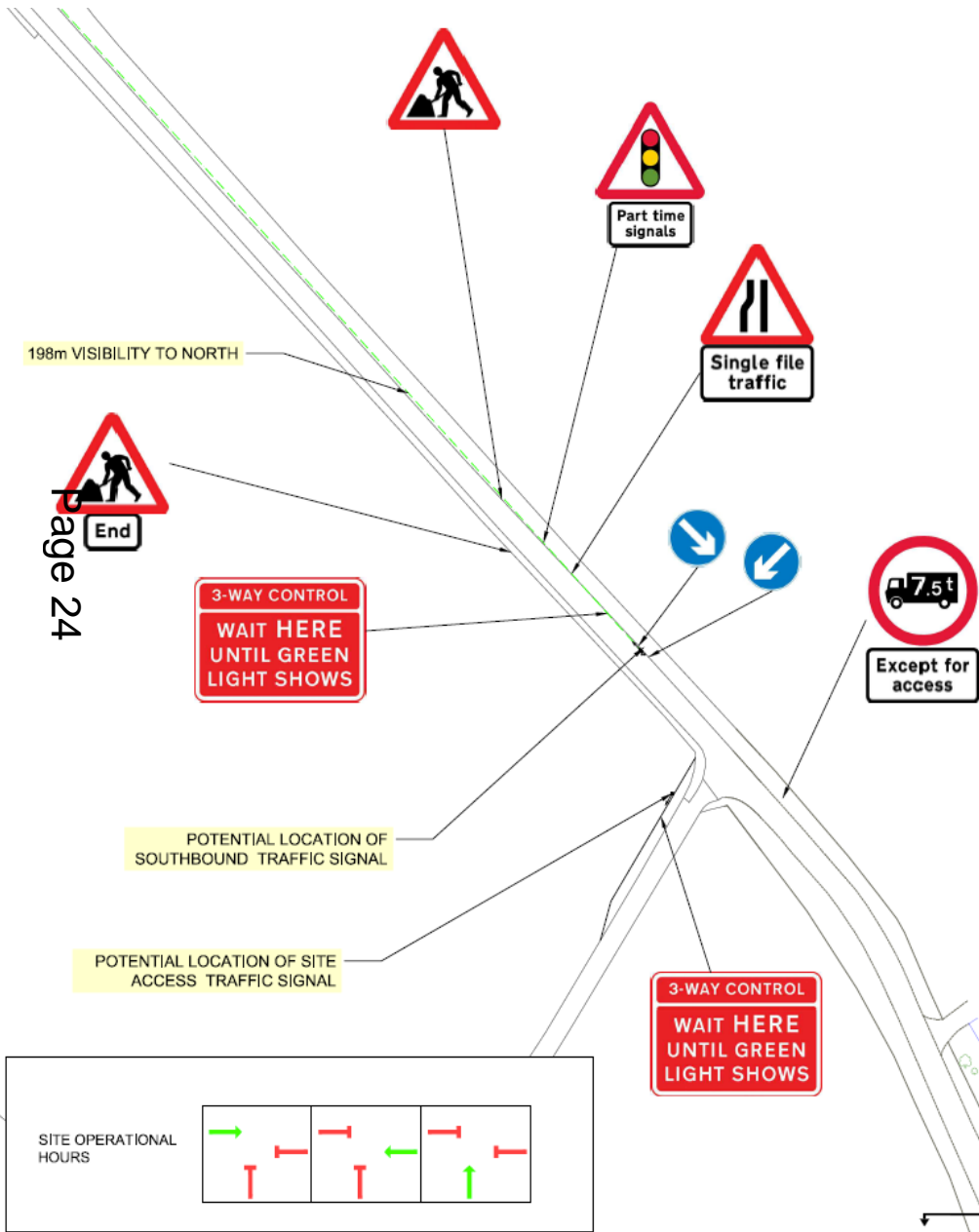

Page 24

KTC KEY TRANSPORT CONSULTANTS LTD
26 BERKELEY SQUARE
BRISTOL
BS8 1HP
Tel : 0117 920 9430
E-mail : info@key-transport.com

**HILL FARM SOLAR SITE
PROPOSED TRAFFIC MANAGEMENT
SIGNAL LOCATION AND STAGING**

1:1,000 @ A3
1115-005B

22

Planning application 19/1610/OUT

Land north of Hinckley Road, Kirby Muxloe

Page 25

Outline application for demolition of existing buildings and erection of up to 885 dwellings, including public open space, land reserved for a primary school, landscaping and associated infrastructure (all matters reserved except means of access)

Site Location

Page 26

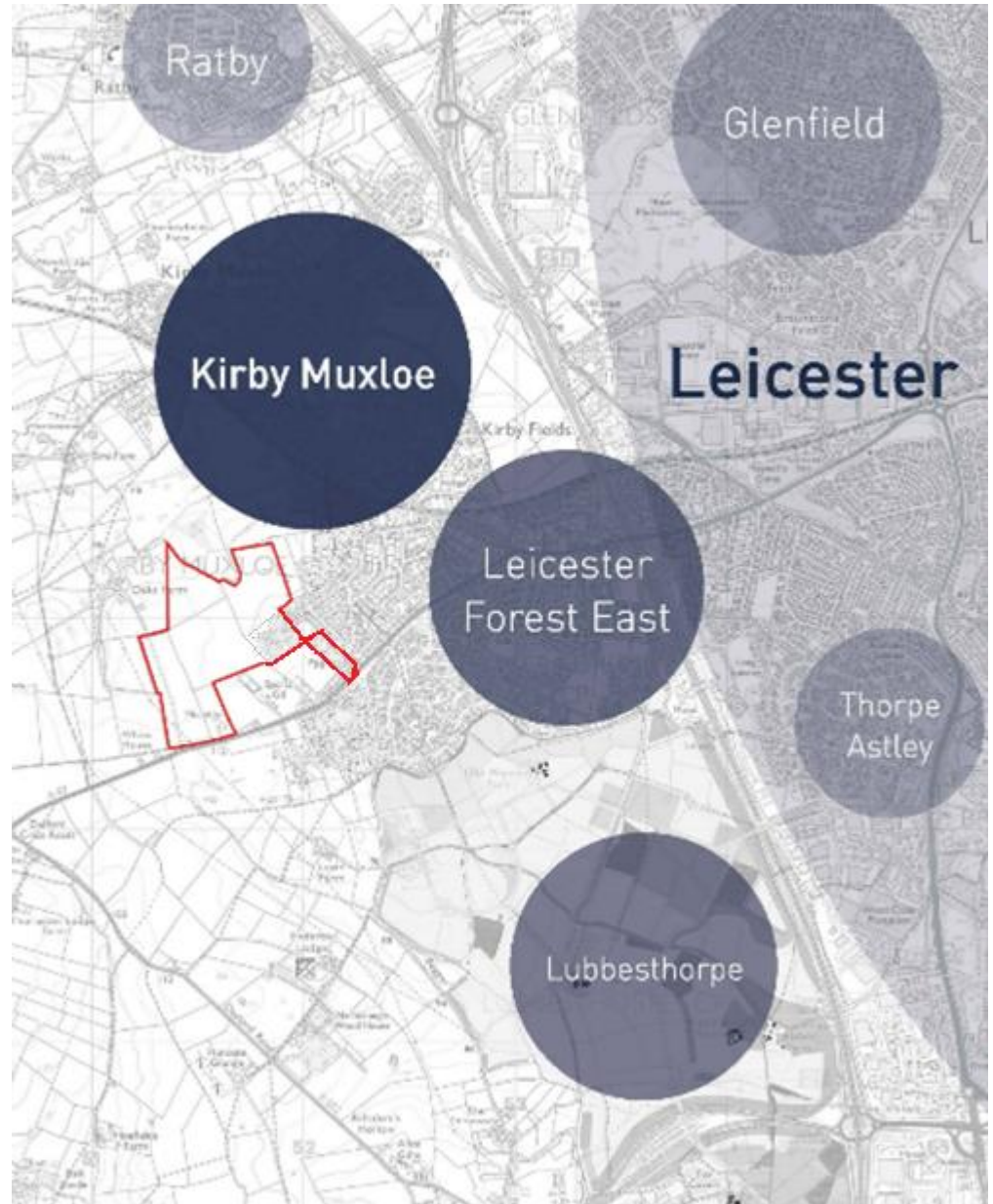

The Site

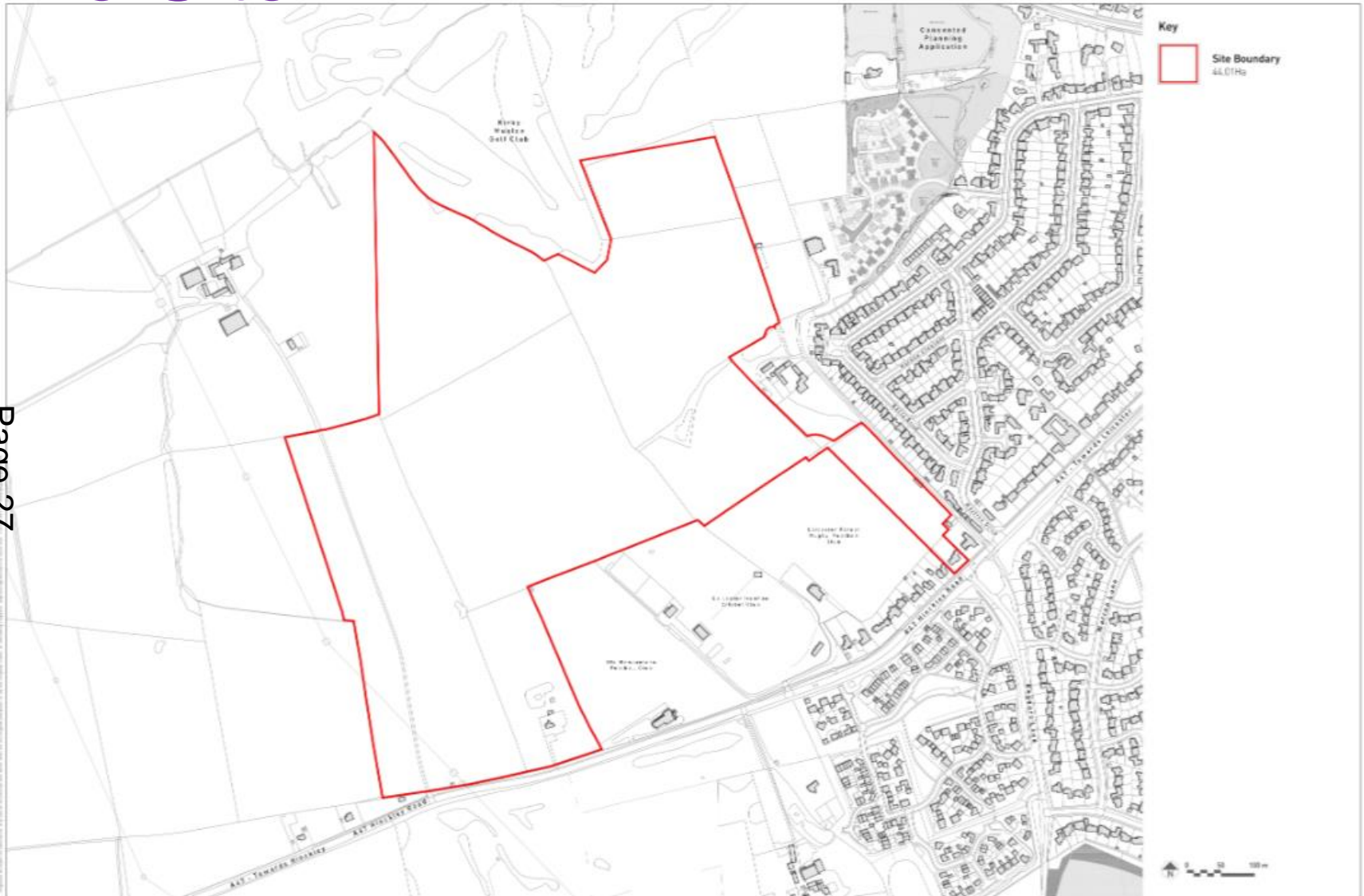

Page 27

Masterplan

Page 29



Masterplan evolution (Initial)

Page 30



Masterplan evolution (Current)



Page 31

Design Code



Design Code Rules

There are **37 rules** that apply everywhere or to specific locations within Hastings Park.

The rules are divided across four parts, working from the macro to the micro scale:

| | | |
|-----------------|-------------------------------------|-----------------|
| 37 RULES | A: The bigger picture | 6 Rules |
| | B: Streets | 2 Rules |
| | C: Civic spaces | 6 Rules |
| | D: Getting the details right | 23 Rules |

Page 32

Page layout and understanding the structure

On each of the pages, you will find the following three types of information, supported by images and diagrams illustrating what is and is not acceptable for that Rule.

UNDERSTANDING THE RULES

The requirements for each of the rules are presented in boxes like this, colour coded to their subsection. Unless otherwise stated, the requirements are mandatory and must be delivered through the design.

ADVICE AND GUIDANCE

Advice and guidance on fulfilling the requirements of the rule is presented in green boxes. These explain how to approach the rule in question, along with how the rule might impact on other rules within the Design Code.





Permitted exceptions



Should exceptions to a rule be permitted, the conditions for this will appear within a box coloured like this one. If this box is not present within the pages covering the rule, then exceptions are not permitted.

Phasing and Severability Plan



Key

-  Site Boundary
44.01Ha

- Development**
-  Phase 1
-  Phase 2
- includes:  School
-  Phase 3
-  Phase 4

- Road Infrastructure**
-  Phase 1
-  Phase 2

- Drainage Infrastructure**
-  Drainage Basins & Swales

- Other**
-  LEAP or agreed equivalent
-  NEAP/MUGA or agreed equivalent

Page 33

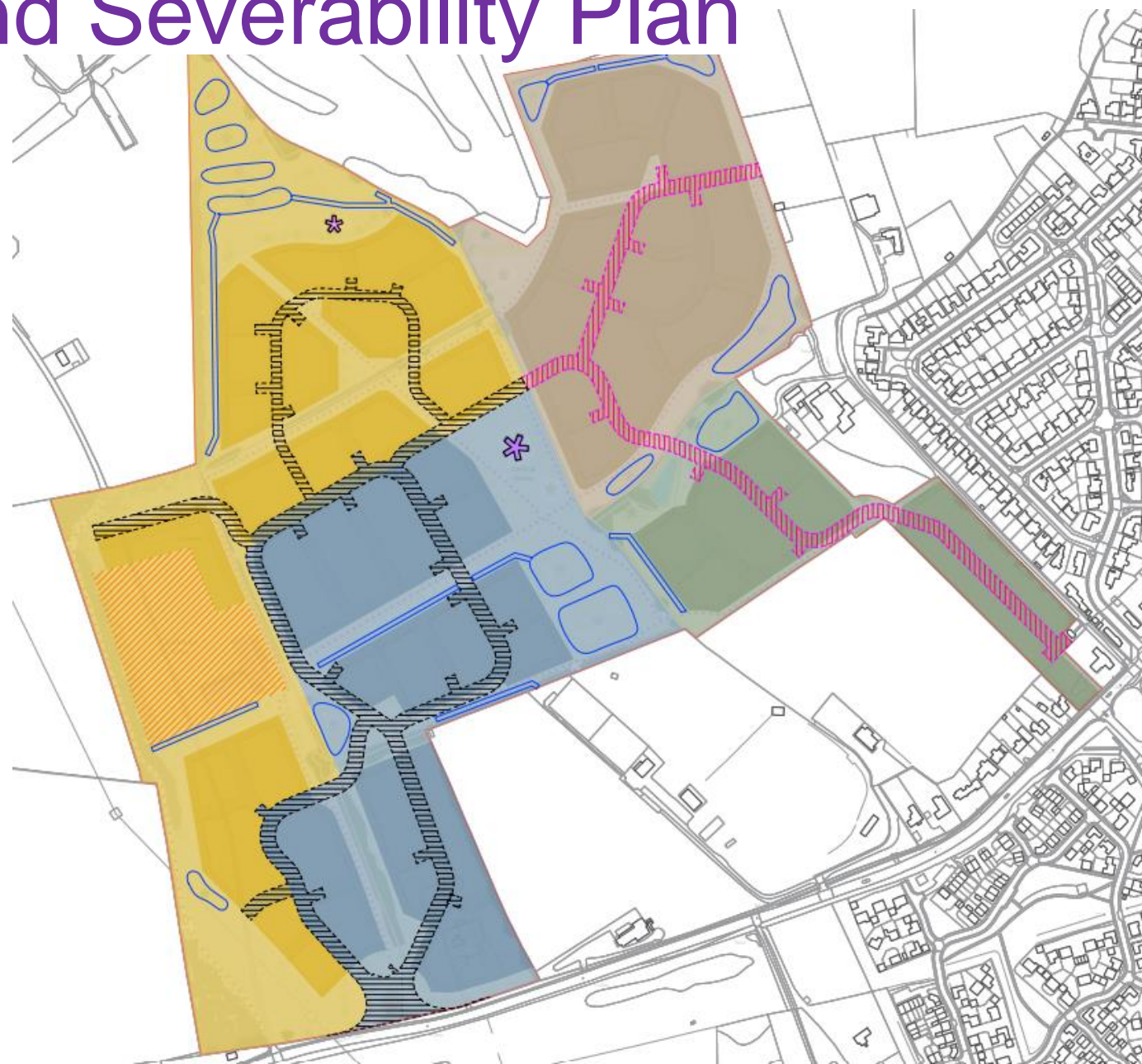

Parameters Plan



Key
 Site Boundary
 44.01Ha

Built Form Parameter

- Built Form**
 Maximum 3.0 storeys - 12m
 (Includes drainage area, open space and internal roads)
- Built Form**
 Maximum 2.5 storeys - 10.5m
 (Includes drainage area, open space and internal roads)
- Built Form**
 Maximum 2 storeys - 9.0m
 (Includes drainage area, open space and internal roads)

Primary School Location

Primary School Playing Fields
 Maximum 1 storeys
 (for buildings associated with school outdoor requirement)

Play Space Location
 LEAP
 (or equivalent)

Play Space Location
 NEAP/MUSA
 (or equivalent)

Access & Movement Parameter

Primary Vehicular Site Access

Primary Vehicular Access Corridor

Secondary Vehicular Access Corridor

Tertiary Vehicular Access Corridors

Realigned Farm Access Track

Pedestrian and/or Cycle Connectivity

Pedestrian/Cycle Connection

Landscape Parameter

Retained Trees & Vegetation
 Except to allow for Access & Movement Parameter & Drainage Areas

Ecological Mitigation Area

Necessary Landscape Mitigation
 Except to allow for Access & Movement Parameter & Drainage Areas

Open Space/Green Corridors
 Except to allow for Access & Movement Parameter includes:
 1. Proposed Landscaping
 2. Drainage Areas & Swales
 3. Pedestrian and/or cycle links
 4. Feature public realm
 5. Vehicle Access to dwellings

Policy context - Allocated site (Policy SA1)



Page 35

Proposed Habitats Plan

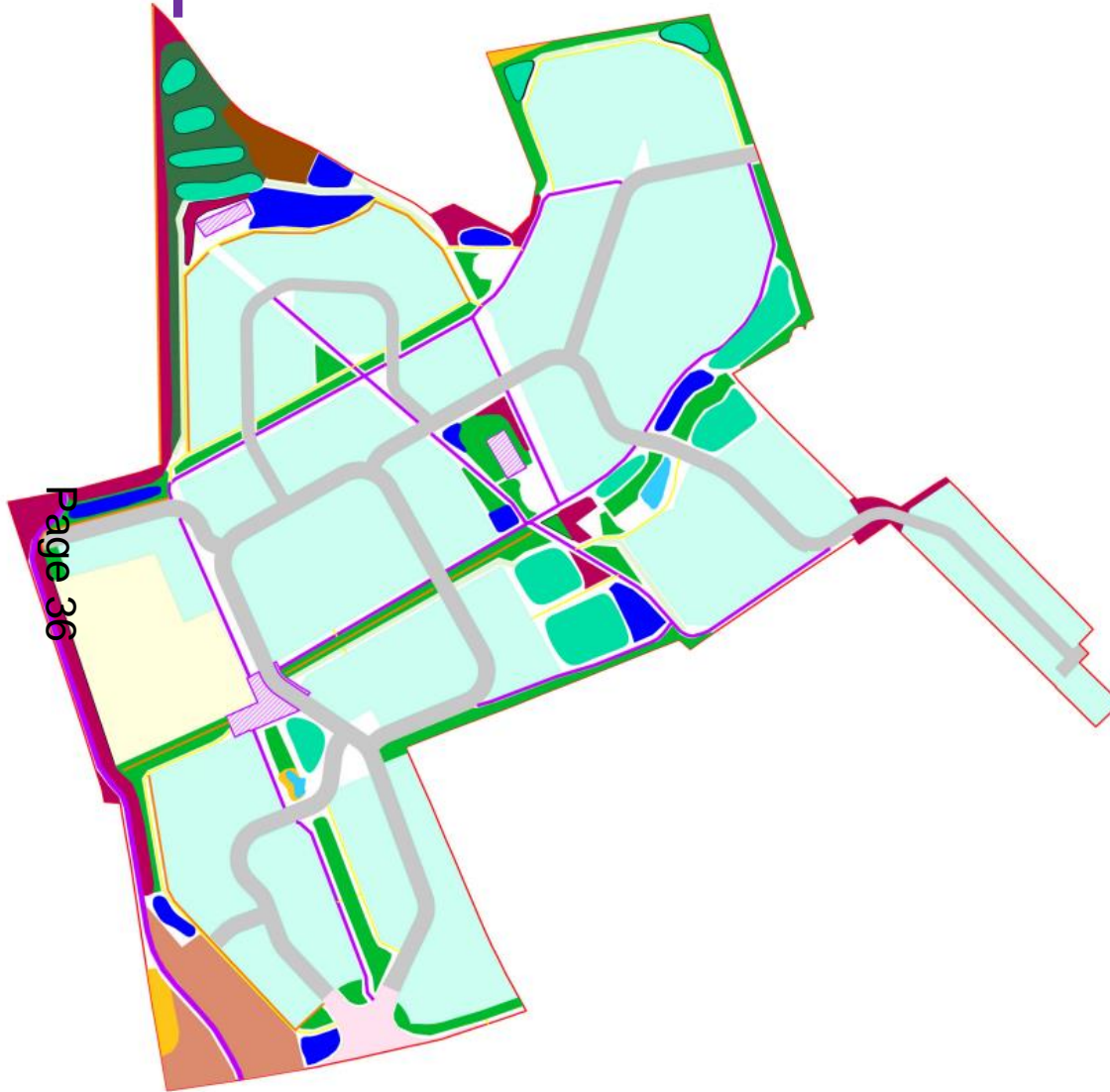

-  Site boundary
-  Housing: 70% buildings and hardstanding (15.279ha), 30% vegetated gardens (6.548ha)
-  Education: 30% hardstanding (0.614ha), 70% open space (1.431ha - split into 70% short-mown modified grassland (1.002ha) and 30% wildflower meadow (0.429ha))
-  S278 works (0.338ha)
-  Primary infrastructure (4.381ha) split into 90% hardstanding (3.943ha) and 10% short-mown modified grassland verges (0.438ha)
-  Hardstanding in POS (1.528ha), farm track, cyclepath, footpath, school drop area and play areas
-  Drainage basins: wet cores (1ha), wet wildflower mix (0.701ha)
-  Wildlife ponds (0.966ha)
-  Traditional orchard (0.287ha)
-  Wildflower meadow, moderate condition (2.805ha)
-  Wildflower meadow, good condition (0.686ha)
-  Thicket planting (1.53ha)
-  Bioswale (0.396ha)
-  Short-mown modified grassland, 55% poor condition (2.26ha), 45% moderate condition (1.849ha)
-  Enhanced grassland (1.093ha)
-  Retained ponds (0.11ha)
-  Retained bramble scrub (0.2ha)
-  Hedgerow planting (1.63km)

Page 36

Landscape and Visual Impact Assessment

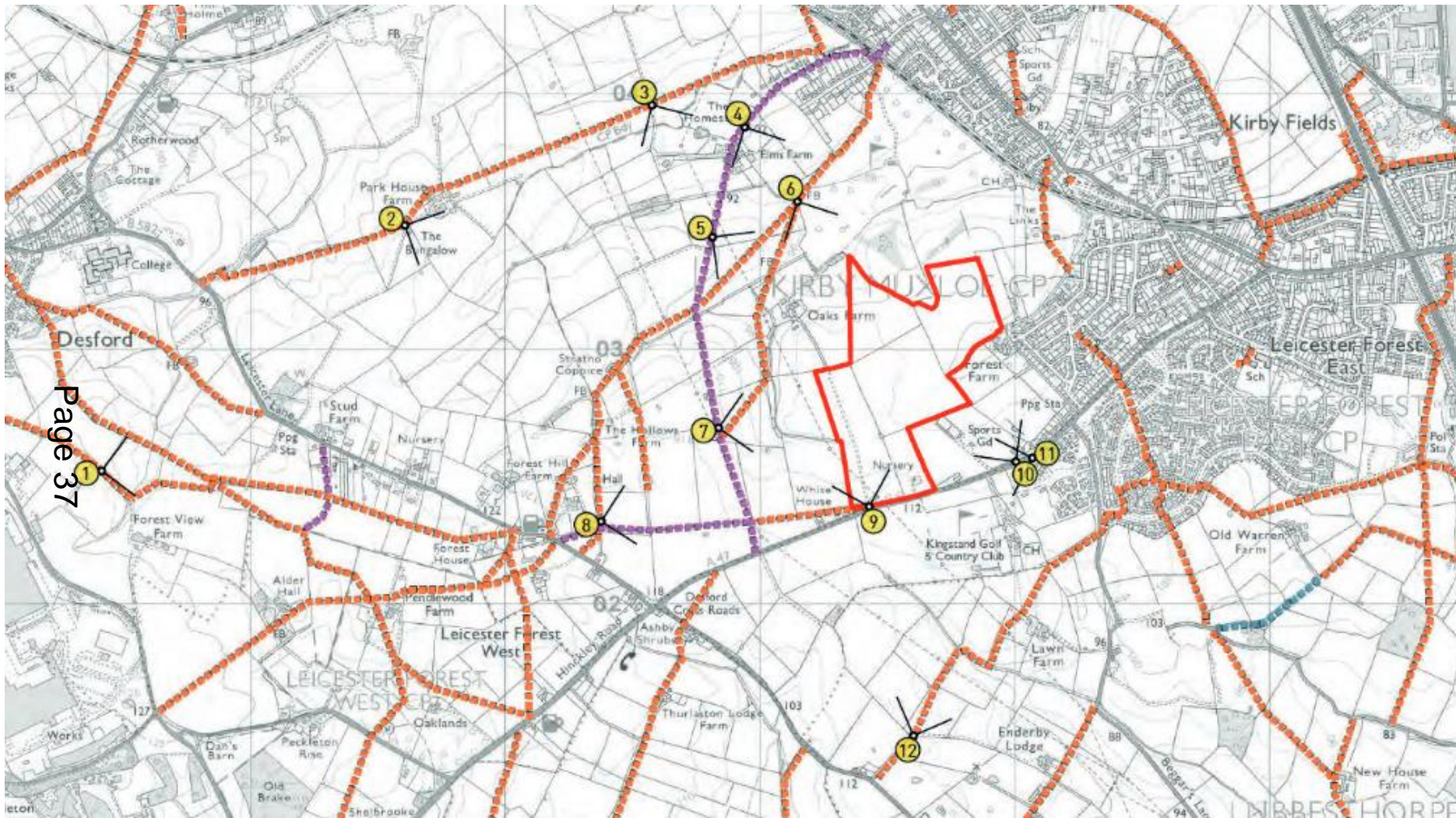

Page 37

Oaks Farm



Plate 16: East-facing wing of Oaks Farmhouse



Plate 18: View looking north from where the access track crosses the northern boundary of the site



Plate 17: South-facing wing of Oaks Farmhouse

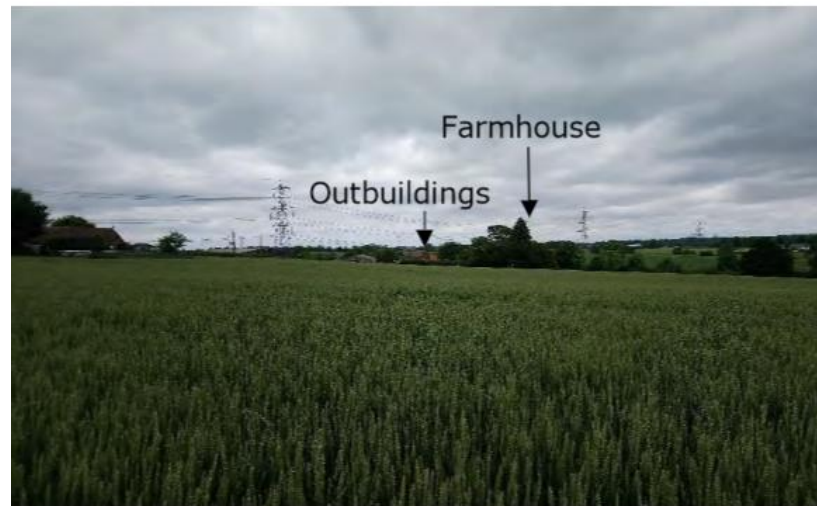
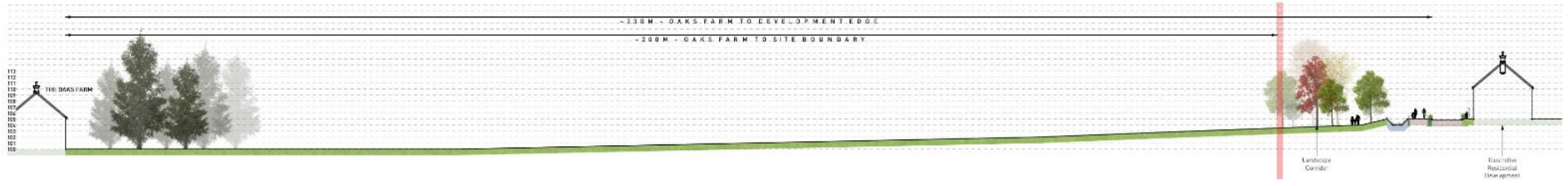

Plate 19: View looking west towards Oaks Farm from the central-northern part of the site

Illustrative section (Oaks Farm)

Page 39



Education provision

Page 40







Open spaces









- Key**
- Illustrative Built Frontage
 - Central Green
 - Entrance Feature
 - Linear Park
 - Northern Green
 - Retained Green Infrastructure
 - Queen's Walk
 - Wetland Public Open Space
 - Woodland Edge

Open space plan

Key

-  Development
-  Road Infrastructure
-  Public Open Space
-  Drainage Areas
-  Wildlife Ponds
-  Retained Trees & Vegetation

Open Space Typologies

-  **Public Open Space**
Parks & Recreation Grounds
-  **Public Open Space**
Natural Greenspace
-  **Public Open Space**
Informal Open Space
-  **Public Open Space**
Children and Young People's Space
-  **Public Open Space**
Public Realm Outside School
-  **Restricted Access West of Realigned Track Access**



'Queens Walk' provides approx. 25 metre wide green route through centre of development.

Central area of green space is approximately the size of 3 football pitches.

This is larger than Narborough Park or just under half the size of Bouskell Park

POS Typologies

- Parks & Recreation Grounds
- Natural Greenspace
- Informal Open Space
- Children and Young People

Off site open space

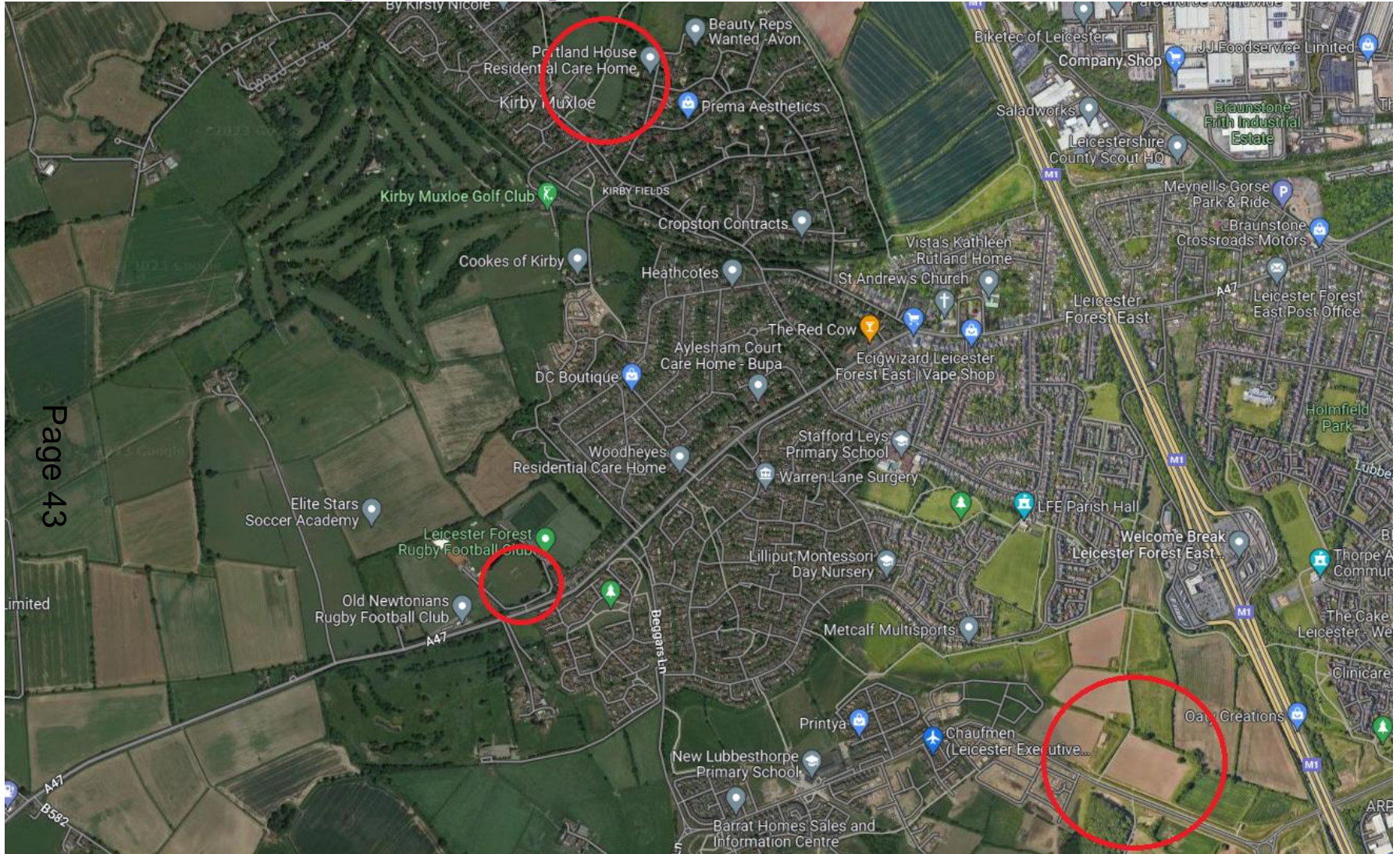

Page 43

Transport and Highways

Page 44

Access and movement plan

Page 45

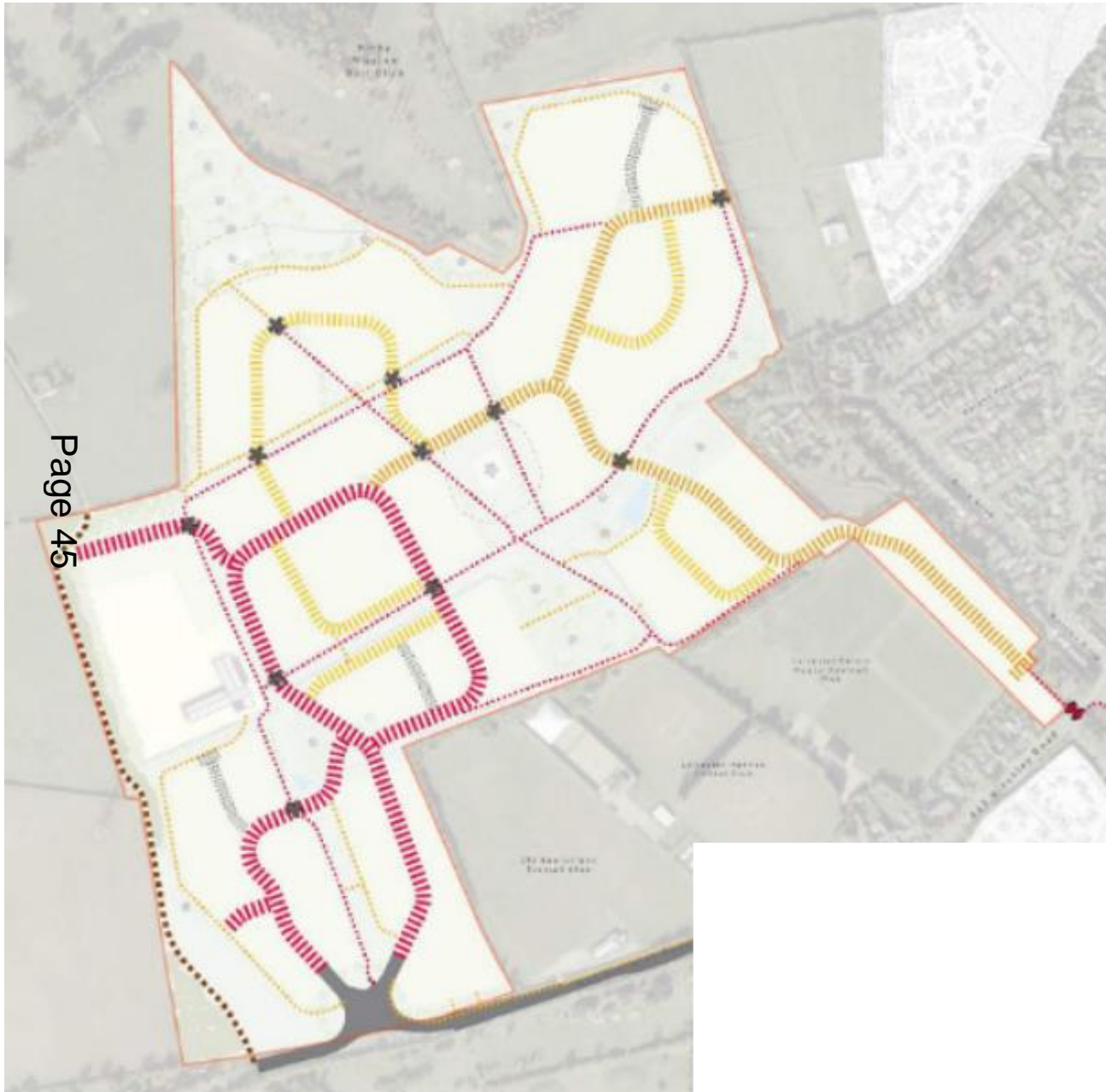

Key

-  Site Access Vectos
-  Primary Street & Eastern Arm
-  Primary Street - Western Arm
-  Secondary Street
-  Tertiary Streets
-  Realigned Track Access to Farm
-  Segregated Cycle Routes
-  Pedestrian and/or Cycle Routes
-  Pedestrian Priority Crossing
-  Pedestrian Connectivity to Routes Adjacent to the Site Boundary

Trip rates

Car/ van drivers
(2028/2033)

| | Arrival | Departure | Total |
|-------------|---------|-----------|-------|
| 2028 | | | |
| AM | 101 | 218 | 319 |
| PM | 176 | 91 | 267 |
| 2033 | | | |
| AM | 202 | 435 | 637 |
| PM | 352 | 182 | 534 |

Multi-modal
(2033)

| | AM | | | PM | | | | |
|--------------------------|---------------|------------|------------|-------------|---------------|------------|------------|------------|
| | Mode share | In | Out | Total | Mode share | In | Out | Total |
| Walk | 26.6% | 113 | 242 | 355 | 12.3% | 67 | 35 | 101 |
| Bicycle | 1.5% | 6 | 13 | 20 | 1.7% | 9 | 5 | 14 |
| Car / van driver | 47.7% | 202 | 435 | 637 | 64.9% | 352 | 182 | 534 |
| Car / van passenger | 15.8% | 67 | 144 | 211 | 13.9% | 75 | 39 | 114 |
| Motorcycle | 0.2% | 1 | 2 | 3 | 0.4% | 2 | 1 | 3 |
| Other private transport1 | 1.1% | 5 | 10 | 15 | 0.4% | 2 | 1 | 3 |
| Other local bus | 4.3% | 18 | 39 | 57 | 2.9% | 15 | 8 | 23 |
| Non-local bus | 0.0% | 0 | 0 | 0 | 0.1% | 0 | 0 | 1 |
| Surface rail | 1.9% | 8 | 18 | 26 | 2.4% | 13 | 7 | 19 |
| Taxi / minicab | 0.6% | 2 | 5 | 7 | 0.8% | 4 | 2 | 6 |
| Other public transport | 0.4% | 2 | 3 | 5 | 0.4% | 2 | 1 | 3 |
| Total | 100.0% | 424 | 912 | 1336 | 100.0% | 542 | 280 | 822 |

Page 46

Proposed roundabout

| Arm | AM (0800 – 0900) | | | PM (1700 – 1800) | | |
|--------------------|------------------|-----------|------|------------------|-----------|------|
| | Queue (Veh) | Delay (s) | RFC | Queue (Veh) | Delay (s) | RFC |
| A47 East | 2.6 | 10.82 | 0.72 | 2.0 | 7.55 | 0.67 |
| A47 West | 1.1 | 6.62 | 0.53 | 3.3 | 13.60 | 0.78 |
| Site Access (West) | 0.2 | 5.18 | 0.17 | 0.1 | 6.08 | 0.09 |
| Site Access (East) | 0.8 | 8.16 | 0.43 | 0.2 | 6.36 | 0.20 |

Page 48

A47/ Beggars Lane junction improvement

| A47 / Beggars Lane Existing / Proposed Junction Layout & Operation | Reference Case | Development Case Existing Layout | Development Case Mitigation Layout |
|--|----------------|----------------------------------|------------------------------------|
| | PRC (%) | PRC (%) | PRC (%) |
| AM 2033 | -14.4 | -37.0 | -2.8 (+11.6) |
| PM 2033 | +10.0 | -3.4 | +8.9 (-1.1) |

Page 50

A47/ Kirby Lane junction improvement

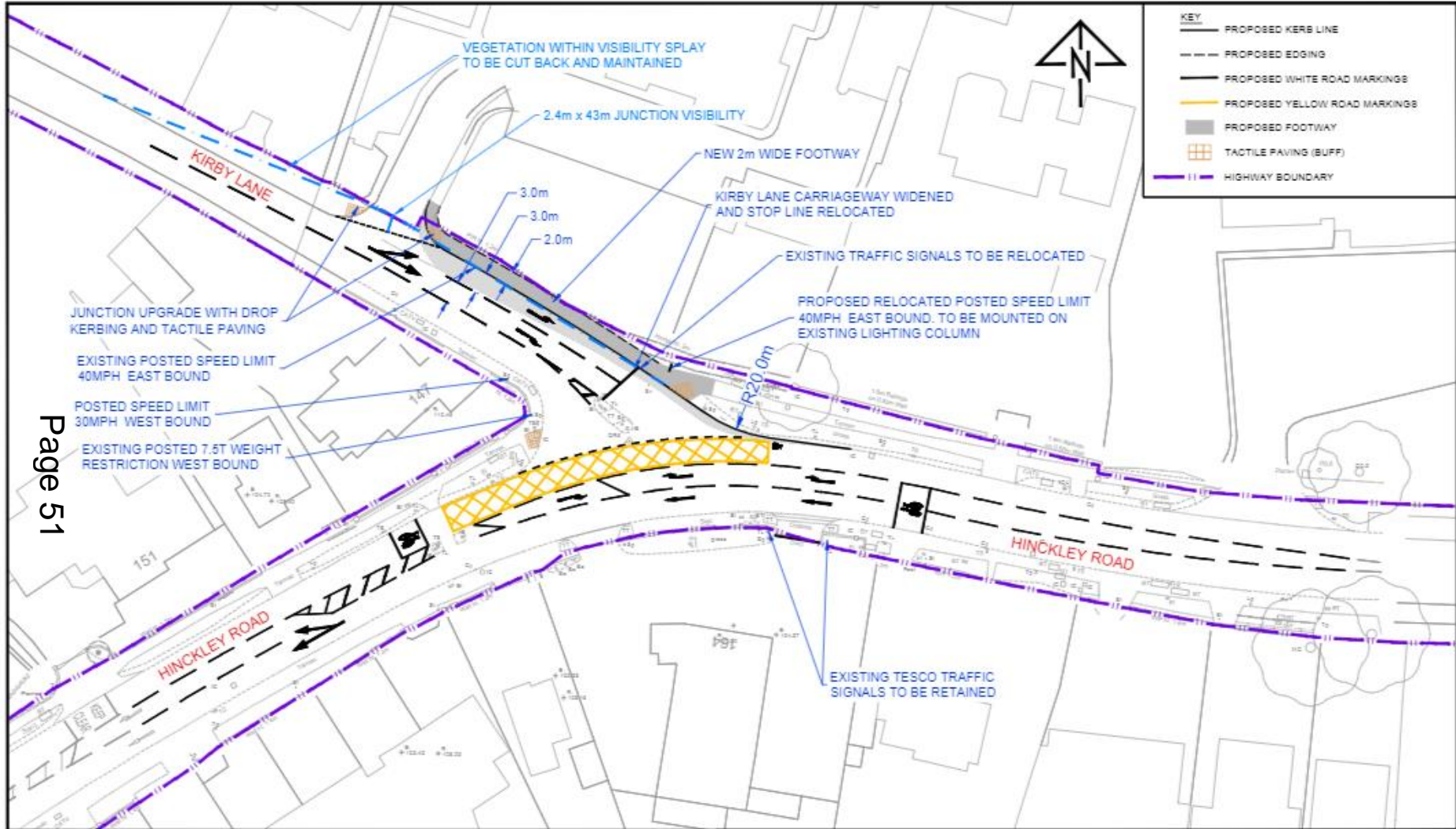

Page 51

A47/ Kirby Lane junction improvement

| A47 / Kirby Lane Existing / Proposed Junction Layout & Operation | Reference Case | Development Case Existing Layout | Development Case Mitigation Layout |
|--|----------------|----------------------------------|------------------------------------|
| | PRC (%) | PRC (%) | PRC (%) |
| AM 2033 | -5.4 | -6.5 | +11.4 (+16.0) |
| PM 2033 | +4.9 | +6.3 | +18.3 (+13.4) |

Page 52

Desford Crossroads

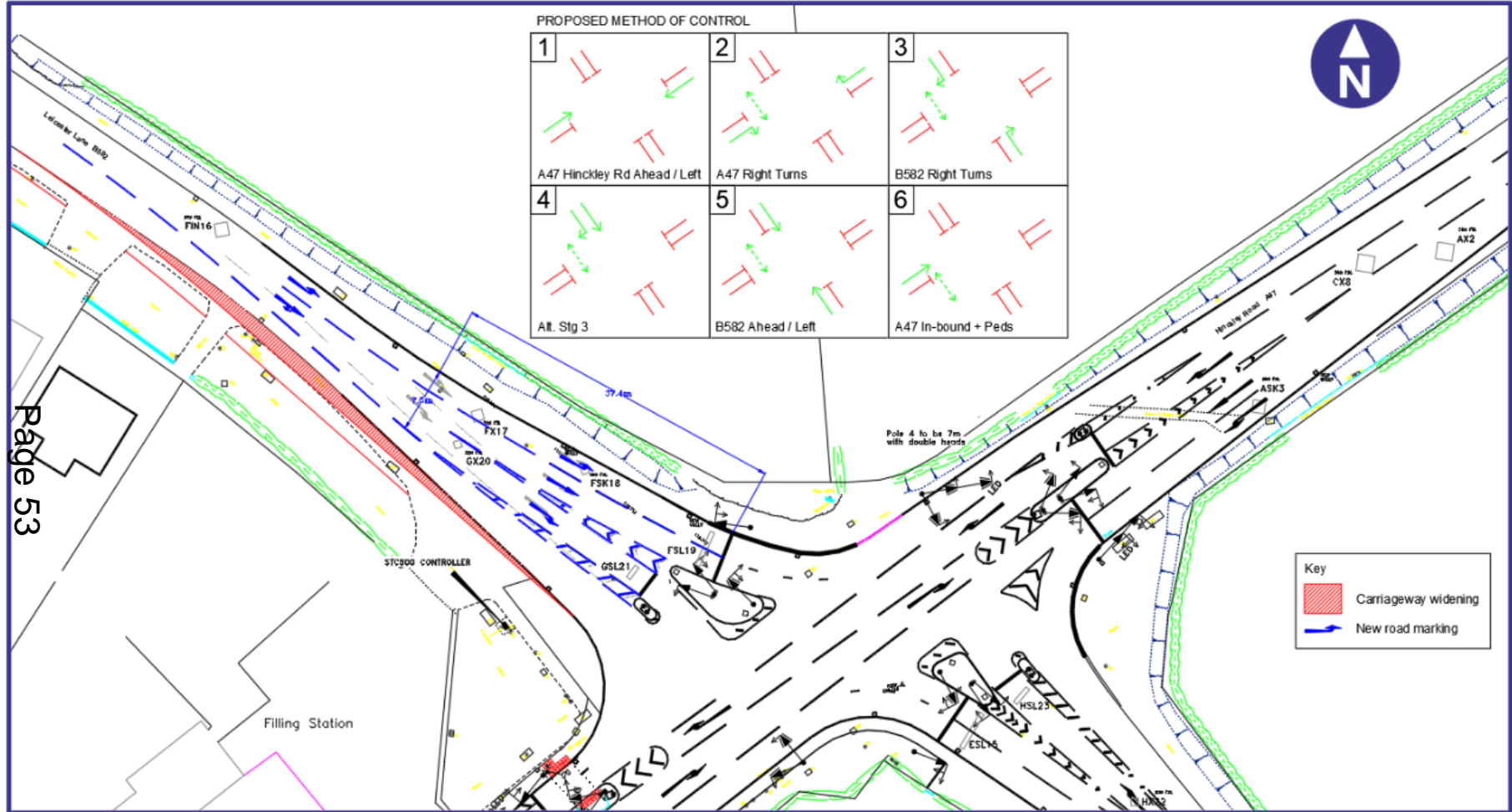

Page 53

Desford Crossroads

| Desford Crossroads Existing / Proposed Junction Layout & Operation | Reference Case | Development Case Existing Layout | Development Case Mitigation Layout |
|--|----------------|----------------------------------|------------------------------------|
| | PRC (%) | PRC (%) | PRC (%) |
| AM 2033 | -5.6 | -5.3 | - 5.3 (+0.3) |
| PM 2033 | -28.9 | -29.3 | -26.9 (+2.0) |

Page 54

Cycle connection to Lubbethorpe – Warren Lane and Forest House Lane

Page 58

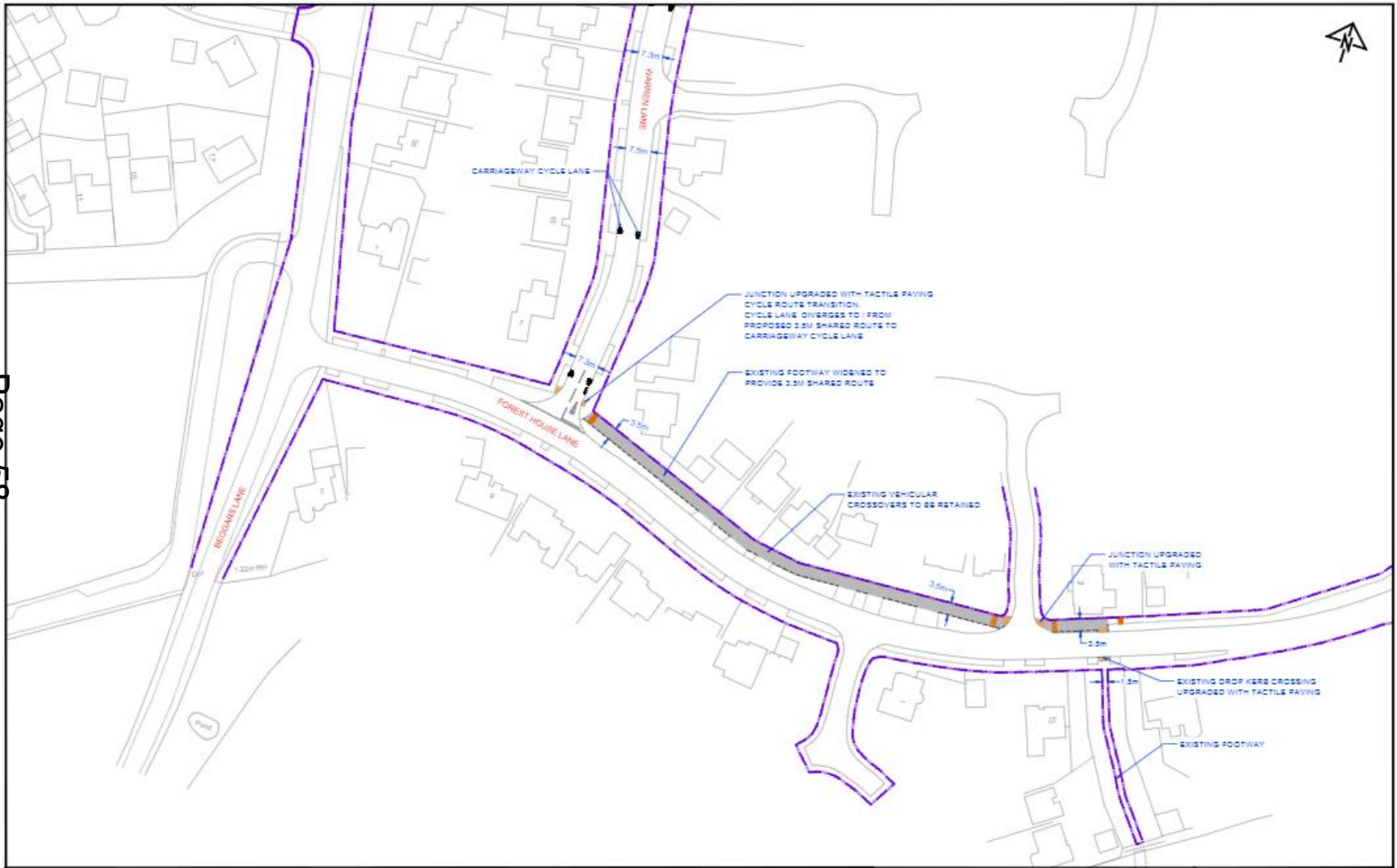

Public Rights of Way

Page 59

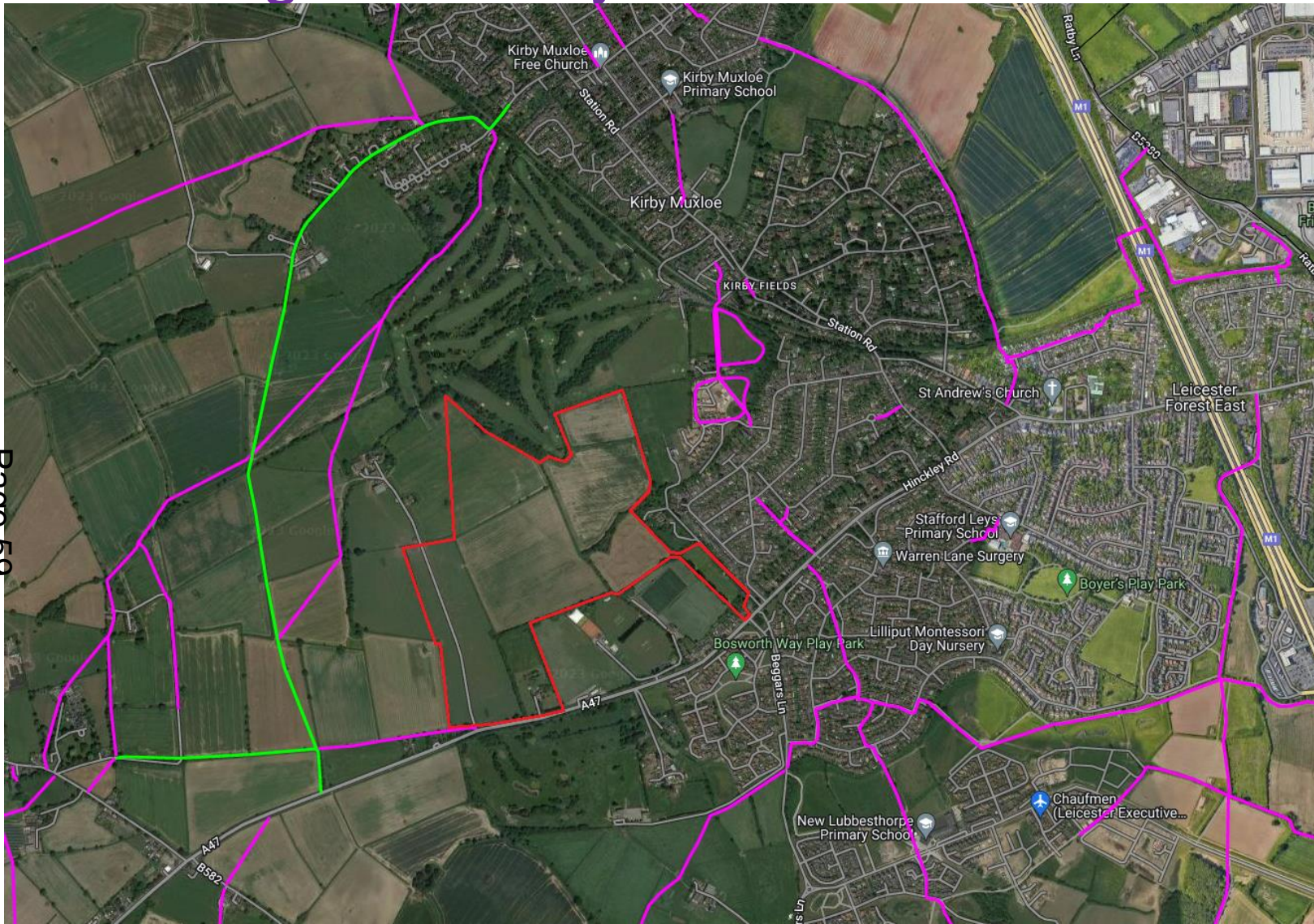

Key:

Application site

Public footpaths

Public bridleways

Existing Bus Stop Radius

Page 60



Proposed Bus Stop Radius

Page 61



Primary Route Potential Bus Stop Radius

Page 62



Conclusion

Page 63

Planning Application 22/0827/RM

Page 64

Reserved matters application for the erection of Local Centre 1 to include commercial units (units 1-3 use class E(a), unit 4 use class E(a) or E(b) and unit 5 use class E(b)), medical centre (use class E(e), potential medical centre expansion or offices (use class E(e) or E(g(i))), 66 bed residential care home (use class C2) together with sub-station and cash point to unit 1 (details of access, appearance, landscaping, layout and scale)

Tay Road, New Lubbesthorpe



Page 65

Site Location

Page 66

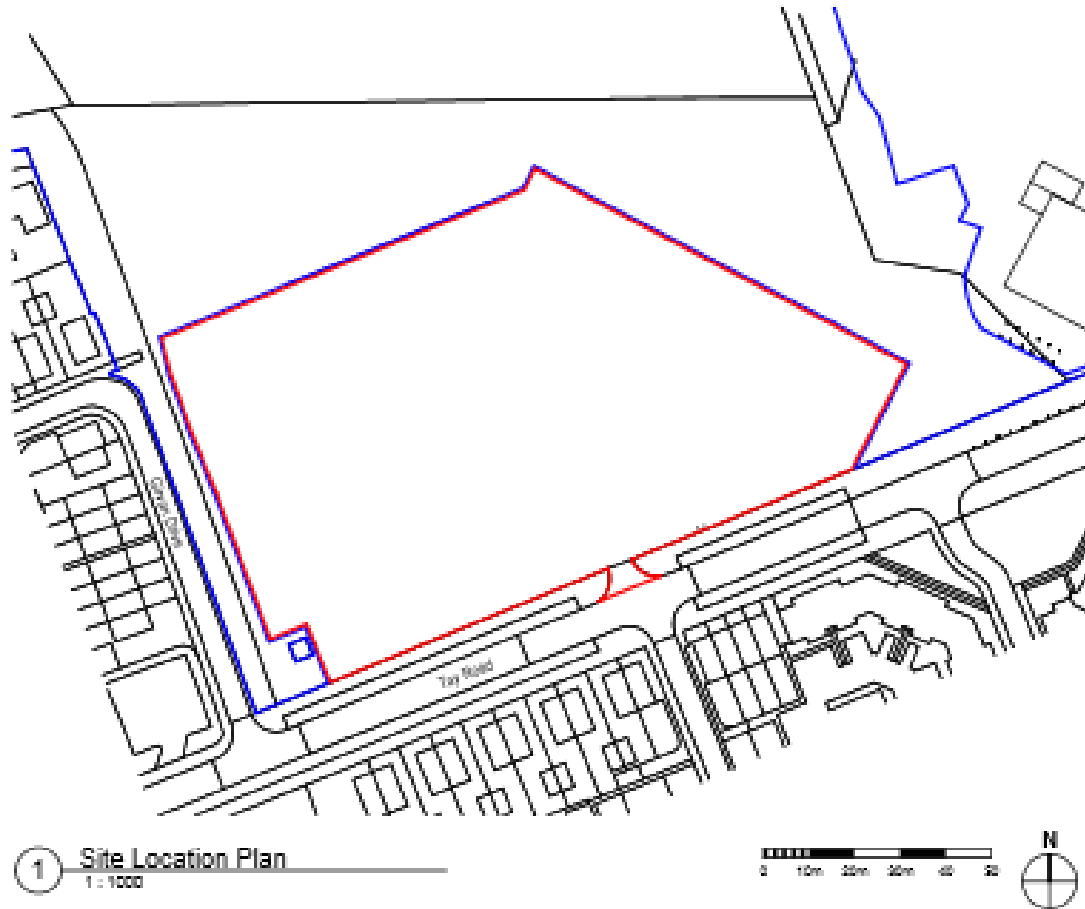

Context Site Location

Local Centre 1 site



Page 67

Site Layout Plan

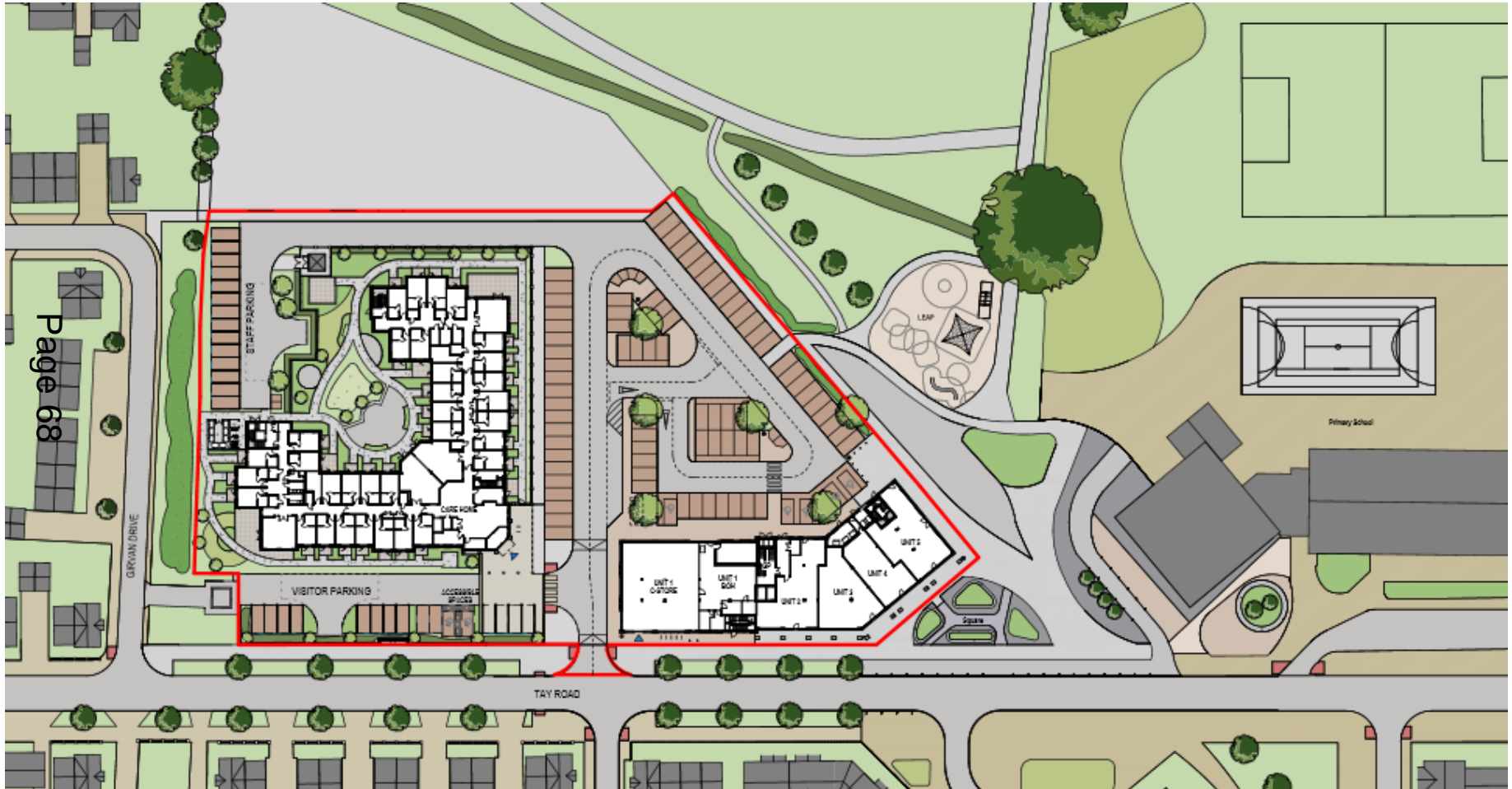

Site Plan - Care Home



Page 69

Street Elevations – Tay Road

Care Home



Page 71

Mixed Use



Care Home Elevations



GA Elev. Elevation C-C
1:100

Page 72



West Elevation E-E
1:100

Integrated bat boxes

Integrated sparrow terrace boxes



Mixed Use Elevations



1 GA North Elevation D-D



page 73

3 GA East Elevation F-F



3 GA West Elevation C-C

Floor Plans – Ground Floor Mixed Use

Page 74

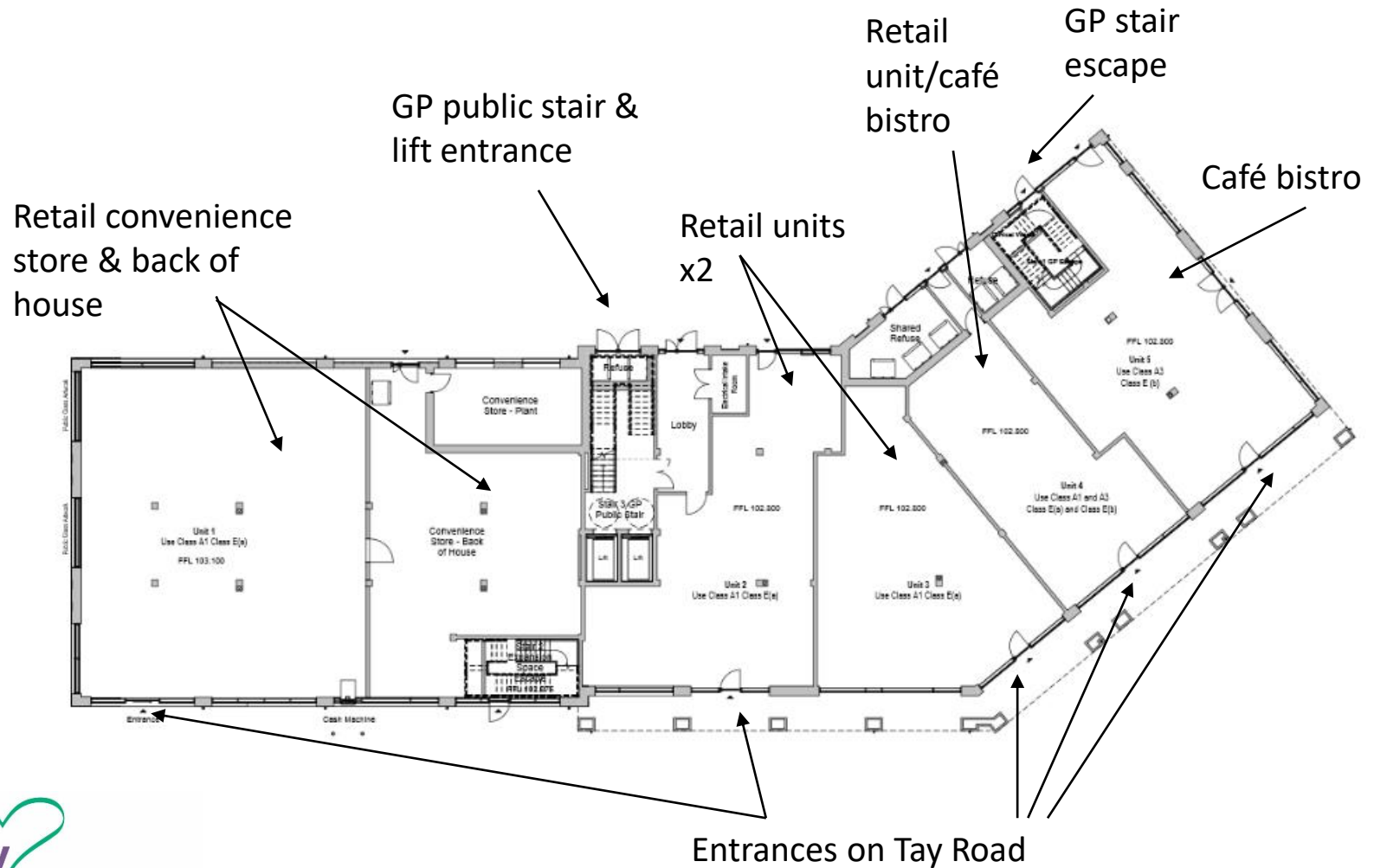

Floor Plans – First Floor Medical Centre

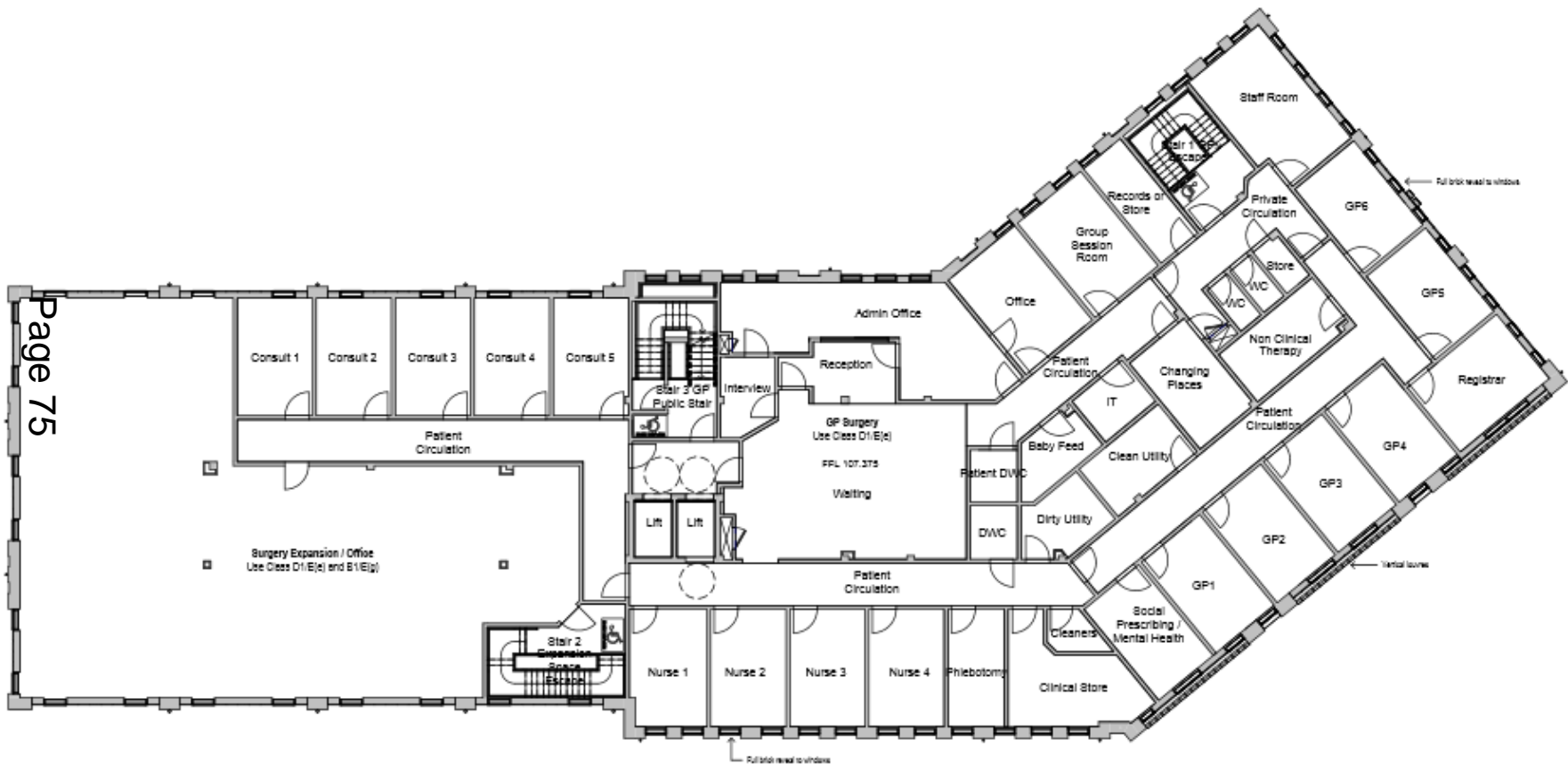

Page 75

Floor Plans - Ground Floor Care Home

- 33 bedrooms on ground & 1st floors (66 in total)
- Private, landscaped courtyard garden
- Reception
- Office
- Café
- Lounges
- Dining rooms
- Outdoor patios
- Communal balconies
- Breakout space
- Hairdressers
- Family room
- Ancillary space
- Kitchen, Laundry, plant & staff facilities on 2nd floor

Page 76



Tay Road Frontage